



TRANS-AMF
AUTOMATIC MAINS FAILURE UNIT
FOR GAS/DIESEL/GASOLINE GENERATORS
WITH J1939 ECUs
User Manual

EMKO ELEKTRONİK A.Ş.
Demirtaş Org. San. Bolg.
Karanfil Sk. No: 6 TR
16369 Bursa / TURKEY

Phone : +90 224 261 1900
Faks : +90 224 261 1912
Url : www.emkoelektronik.com.tr
E-mail : emko@emkoelektronik.com.tr
exposales@emkoelektronik.com.tr

CONTENTS

1.Introduction.....	Page	4
1.1 General Specifications.....	Page	4
1.2 Warranty.....	Page	4
1.3 Maintenance	Page	4
1.4 Order Information.....	Page	4
2.Installation.....	Page	5
2.1 Unit Configuration.....	Page	5
2.2 Panel Mounting.....	Page	5
Figure 2.1 Front View.....	Page	5
Figure 2.2 Panel Cut-Out.....	Page	5
2.3 Electrical Connection.....	Page	6
3.Definition Of Front Panel And Accessing To The Parameters.....	Page	7
3.1 Front Panel Description.....	Page	7
3.2 Accessing To The Operator Parameters.....	Page	17
3.3 Accessing To The Technician Parameters.....	Page	18
3.4 Changing And Saving Parameter Values	Page	25
4.Parameters.....	Page	26
4.1 Operator Parameters.....	Page	26
4.1.1 Mains.....	Page	26
4.1.2 Generator.....	Page	26
4.2 Technician Parameters.....	Page	28
4.2.1 System.....	Page	28
4.2.2 Mains.....	Page	34
4.2.3 Generator.....	Page	34
4.2.4 Engine.....	Page	38
4.2.5 Inputs.....	Page	51
4.2.6 Outputs.....	Page	67
4.2.7 Timers.....	Page	76
4.2.8 Expansion Modules.....	Page	77
4.2.9 Synchronization	Page	78
4.2.10 User Adjustment.....	Page	79
5.Specifications.....	Page	83
6.Other Informations.....	Page	84

EU DECLARATION OF CONFORMITY

Manufacturer's Name : EMKO ELEKTRONIK A.S.
Manufacturer's Address : DOSAB, Karanfil Sk., No:6,
16369 Bursa, TURKEY

This declaration is issued under the sole responsibility of the manufacturer.

Product Name : Automatic Mains Failure Unit
Type Number : TRANS-AMF
Product Category : Electrical equipment for measurement, control and laboratory use

The product(s) that are stated above are fully in conformity with the essential requirements of Council Directives:

2014 / 35 / EU The Low Voltage Directive

2014 / 30 / EU The Electromagnetic Compatibility Directive

This declaration is based on the full compliance of the products with the following European standards:

EN 61000-6-4:2007 EMC Generic Emission Standard for Industrial Environments

EN 61000-6-2:2005 EMC Generic Immunity Standard for Industrial Environments

EN 61010-1:2010 Safety Requirements for electrical equipment for measurement, control and laboratory use

EN 60947-6-1:2005/A1:2014 Low - voltage switchgear and controlgear - Part 6-1: Multiple function equipment - Transfer switching equipment

When and Where Issued

02nd March 2017

BURSA-TURKEY

Authorized Signature

Name : Serpil YAKIN

Position : Quality Manager

1. Introduction

1.1 General Specifications

The unit provides for automatic transfer of a load from mains to generator in the event of a mains failure. Intended for unattended operation, it is able to detect failure of any phase of the mains and to start and switch over to a generator if the mains voltage goes outside pre-set limits. Both automatic and manual control is possible. A test mode is also available which allows the generator to be run without taking the load.

The unit has Dual Working feature. In the event of a mains failure, group with high priority starts and takes the load. If both groups has no priority, the group with less working hour will start and take the load. To use Dual Working feature Dual Set expansion module must be used.

The unit calculates engine RPM from Magnetic Pickup sensor input (MPU) and/or generator voltage signal.

The unit monitors J1939 ECU messages and provides remote start/stop control via J1939 protocol (supported ECUs: Volvo EMS2, Volvo EDC4, Perkins, Scania S6, MAN MFR and standard messages).

The unit is extensively programmable through the front panel, with password protection on two levels. Operational parameters can also be monitored and controlled from a PC via a built-in USB communication port.

In the event that the engine fails to start on the first attempt, the attempt will be repeated a programmed number of times or until successful.

The unit monitors generator operation and gives warning of any faults that are detected. If a fault is detected, the unit shuts down the engine and shows the failure message on the LCD display and activates the internal sounder.

The configurable input-3 can be used as the water level sensing input.
The configurable input-7 can be used as the cabin temperature analog input.

The unit has got the "Event Log" that will record last 500 events.

1.2 Warranty

EMKO Elektronik warrants that the equipment delivered is free from defects in material and workmanship. This warranty is provided for a period of two years. The warranty period starts from the delivery date. This warranty is in force if duty and responsibilities which are determined in warranty document and instruction manual performs by the customer completely.

1.3 Maintenance

Repairs should only be performed by trained and specialized personnel. Cut power to the device before accessing internal parts.

Do not clean the case with hydrocarbon-based solvents (Petrol, Trichlorethylene etc.). Use of these solvents can reduce the mechanical reliability of the device. Use a cloth dampened in ethyl alcohol or water to clean the external plastic case.

1.4 Order Information

Trans-AMF: Automatic mains failure unit with USB communication

Trans-AMF.RS485: Automatic mains failure unit with USB and RS-485 communication

2. Installation



Before beginning installation of this product, please read the instruction manual and warnings below carefully.

A visual inspection of this product for possible damage occurred during shipment is recommended before installation. It is your responsibility to ensure that qualified mechanical and electrical technicians install this product.

If there is danger of serious accident resulting from a failure or defect in this unit, power off the system and separate the electrical connection of the device from the system.

Keep the power off until all of the wiring is completed so that electric shock and trouble with the unit can be prevented.

To reduce the effect of electrical noise on device, Low voltage line (especially sensor input cable) wiring must be separated from high current and voltage line.

If possible, use shielded cable and shield must be connected to ground only one side.

Before commissioning the device, parameters must be set in accordance with desired use. Incomplete or incorrect configuration can cause dangerous situations.

2.1 Unit Configuration

The unit can be programmed using the buttons and LCD display on the front panel or PC Software.

2.2 Panel Mounting

The unit is designed for panel mounting. Fixing is by two screw fixings.

1- Insert the unit in the panel cut-out from the front.

2- Insert the fixings in the slotted at the corners of the unit and tighten the fixing screws to secure the unit against the panel.



During the equipment is putted in hole on the metal panel while mechanical installation some metal burrs can cause injury on hands, you must be careful.

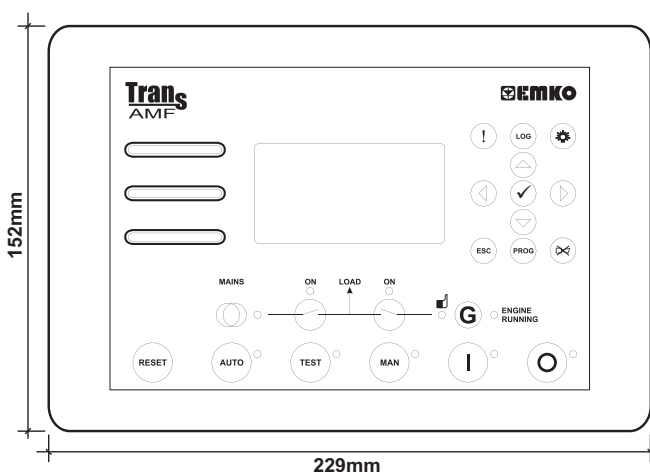

Figure 2.1 Front View

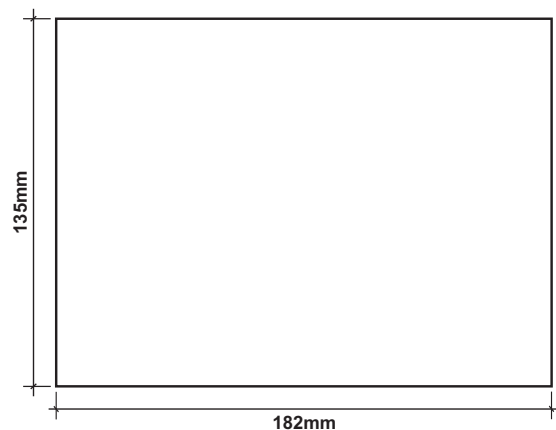
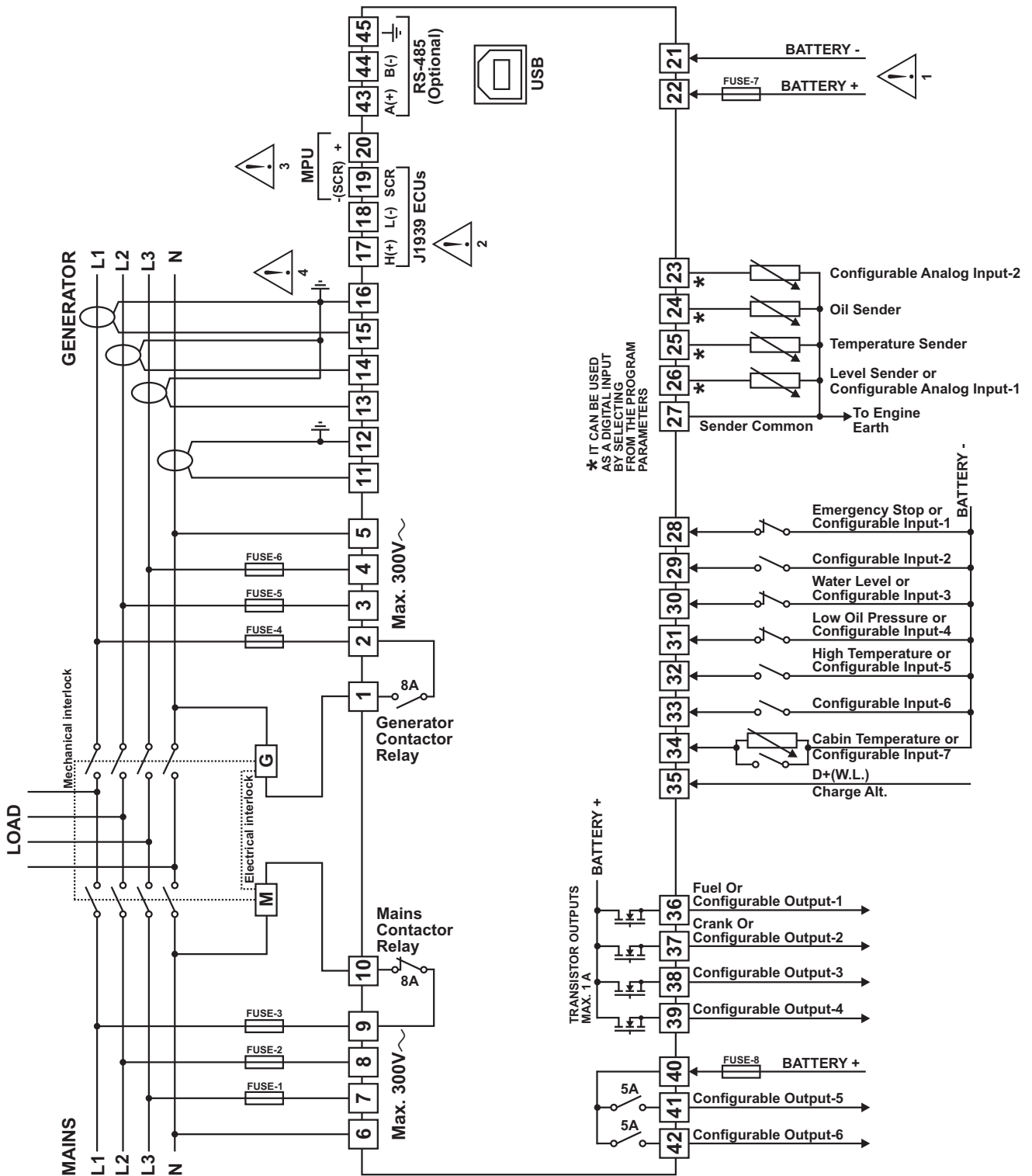

Figure 2.2 Panel Cut-Out

2.3 Electrical Connection

TRANS-AMF three phase connections schematic



FUSE-1, FUSE-2, FUSE-5, FUSE-6 2A.T
 FUSE-7 6A.T
 FUSE-8 Max. 10A.T

FUSE-3, FUSE-4 8A.T



- 1- Connect the unit as shown in the appropriate diagram. Be sure to connect the battery supply the right way round and battery negative should be grounded.
- 2- The CAN interface requires that a 120 Ohms terminator is fitted to each end of the communications link. This termination resistor is fitted internally into the unit. So it is not required externally. The screen is grounded at one end ONLY.
- 3- Screened cable must be used for connecting the Magnetic Pickup, ensuring that the screen is grounded at one end ONLY.
- 4- Current transformers secondary should be grounded. The CT of 5VA is recommended.

3. Front Panel Description And Accessing To The Parameters

3.1 Front Panel Description

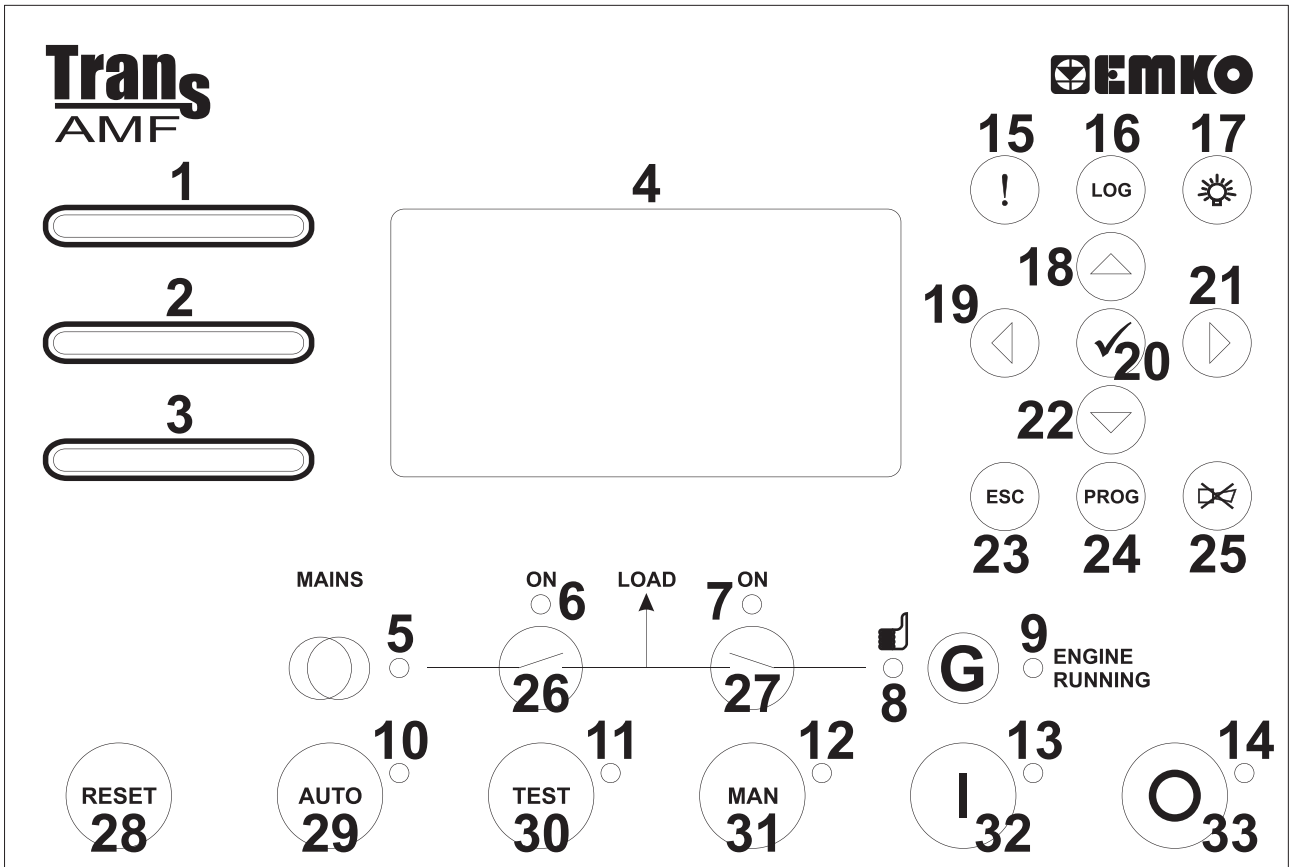

Number	Comment
1	This LED indicates that a "Shutdown" alarm was detected.
2	This LED indicates that a "Warning" alarm was detected
3	This LED indicates that a "Maintenance" alarm was detected
4	This LCD display is used for displaying the electrical measurements during normal operation, and editing/inspecting programming parameters in program mode.
5	This LED indicates that Mains voltage and frequency is within limits and is ready to take over the load.
6	This LED shows that the load is supplied from the mains.
7	This LED shows that the load is supplied from the generator.
8	This LED indicates that Generator voltage and frequency is within limits and is ready to take over the load.
9	This LED indicates that the engine has started and is running.
10	This LED shows that the unit is in the AUTO mode.
11	This LED shows that the unit is in the TEST mode.
12	This LED shows that the unit is in the MANUAL mode.
13	In the MAN, AUTO and TEST modes, this LED indicates that the engine is starting up or is running.
14	This LED shows that the unit is in the STOP mode.

Number	Comment
15	Warning and Alarm messages shortcut button.
16	Event Logs shortcut button.
17	The LAMP TEST button illuminates all LED indicators.
18	This button is used for showing previous parameters on the currently selected page in normal operation. In Programming mode, it operates as an Up button (changing cursor position) or Increment button (increase parameter value).
19	This button is used for showing previous page in normal operation. In Programming mode, it operates as an Left button (changing cursor position).
20	This button is used for entering parameter edit section and saving parameter value in programming mode.
21	This button is used for showing next page in normal operation. In Programming mode, it operates as an Right button (changing cursor position).
22	This button is used for showing next parameters on the currently selected page in normal operation. In Programming mode, it operates as an Down button (changing cursor position) or Decrement button (decrease parameter value).
23	The Escape button is used for exit previous section in programming mode.
24	When this button is pressed, the unit goes into its PROGRAMMING Mode.
25	This button will silence the alarm horn after a failure has been detected.
26	This button opens or closes the mains contactor, only operative when manual mode is selected.
27	This button opens or closes the gen. contactor, only operative when manual mode is selected.
28	This button will reset the controller after a failure has been detected.
29	The AUTO button is used for changing operating mode of the unit to the AUTO Mode.
30	The TEST button is used for changing operating mode of the unit to the TEST Mode.
31	The MAN button is used for changing operating mode of the unit to the MANUAL Mode.
32	The START button is used for starting the engine when the unit is in the Manual Mode.
33	The STOP button is used for changing operating mode of the unit to the STOP Mode. The generator is stopped.

LCD display Description

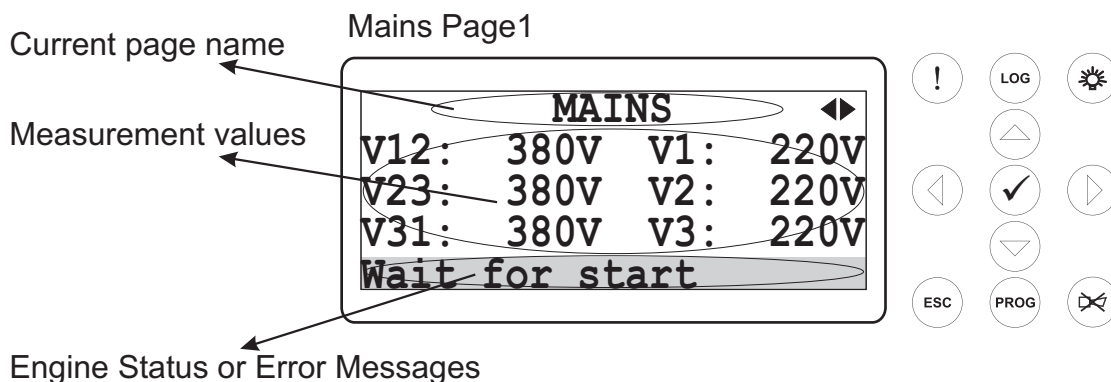

128x64 Dot-matrix LCD display.

Use the Next and Previous buttons to select which Data display page (screen) is to be displayed.

When the Alarm (!) shortcut button is pressed, the Warning & Alarm display page is displayed.

When the Event log (LOG) shortcut button is pressed, the Event Log display page is displayed.

Data display pages on the LCD display;

Mains Page1:

```
MAINS ◀▶
V12: 380V V1: 220V
V23: 380V V2: 220V
V31: 380V V3: 220V
Wait for start
```

V12: Mains voltage L1-L2
V23: Mains voltage L2-L3
V31: Mains voltage L3-L1
V1: Mains voltage L1-N
V2: Mains voltage L2-N
V3: Mains voltage L3-N

Mains Page2:

```
MAINS ◀▶
Fq: 50.0Hz
Phase seq.: L1 L2 L3
Wait for start
```

Fq: Mains frequency
Phase Seq.: Mains phase sequence

Generator Page1:

```
GENERATOR ◀▶
V12: 380V V1: 220V
V23: 380V V2: 220V
V31: 380V V3: 220V
On load
```

V12: Generator voltage L1-L2
V23: Generator voltage L2-L3
V31: Generator voltage L3-L1
V1: Generator voltage L1-N
V2: Generator voltage L2-N
V3: Generator voltage L3-N

Generator Page2:

```
GENERATOR ◀▶
I1: 26A PF1: -0.84
I2: 23A PF2: -0.80
I3: 25A PF3: -0.82
On load
```

I1: Load Current L1
I2: Load Current L2
I3: Load Current L3
PF1: Generator power factor L1
PF2: Generator power factor L2
PF3: Generator power factor L3

Generator Page3:

```
GENERATOR ◀▶
Fq: 50.0Hz Ie: 0A
Phase seq.: L1 L2 L3
On load
```

Fq: Generator frequency
Ie: Earth Current
Phase Seq.: Generator phase sequence

Generator Page4:

```
GENERATOR ◀▶
P1: 170kW
P2: 170kW
P3: 170kW
On load
```

P1: Generator active power L1
P2: Generator active power L2
P3: Generator active power L3

Generator Page5:

GENERATOR		◀▶
Q1:	40kVAr	
Q2:	40kVAr	
Q3:	40kVAr	
On load		

Q1: Generator reactive power L1
Q2: Generator reactive power L2
Q3: Generator reactive power L3

Generator Page6:

GENERATOR		◀▶
S1:	210kVA	
S2:	210kVA	
S3:	210kVA	
On load		

S1: Generator apparent power L1
S2: Generator apparent power L2
S3: Generator apparent power L3

Generator Page7:

GENERATOR		◀▶
ΣP:	510kW	
ΣQ:	120kVAr	
ΣS:	630kVA	
On load		

ΣP: Generator total active power
ΣQ: Generator total reactive power
ΣS: Generator total apparent power

Generator Page8:

GENERATOR		◀▶
kWh :	30600	
kVArh:	7200	
On load		

kWh: Generator active energy
kVArh: Generator reactive energy

Engine Page1:

ENGINE		◀▶
Oil Pressure:	4.3bar	
Temperature :	30°C	
Speed :	1500rpm	
On load		

Oil pressure: Oil pressure sender input value
Temperature: Coolant temperature sender input value
Speed: Engine speed

Engine Page2:

ENGINE		◀▶
Conf.AI1 :	96%	
Conf.AI2 :	40°C	
Battery volt:	12.0Vdc	
On load		

Conf. AI1: Configurable Analog Input-1 value
Conf. AI2: Configurable Analog Input-2 value
Battery volt: Battery supply voltage

Engine Page3:

```

ENGINE ◀▶
Gen.chg.volt: 11.8Vdc
Run times : 7
Crank times : 11
On load

```

Gen.chg.volt: Charge generator voltage
Run times: Number of generator runs
Crank times: Number of generator starts

Engine Page4:

```

ENGINE ◀▶
W.Hour_Min: 2 57
Cabin temp: 26°C
Lt/Hours: 30/2
On load

```

W.Hour_Min: Engine running time (Hour and Minute)
Cabin temp: Cabin temperature
Lt/Hours: Fuel consumption

Engine Maintenance Page:

```

ENGINE MAINTENANCE ◀▶
Next hours : 5000
Next days : 180
Last date: 15/02/2011
On load

```

Next hours: The remaining hour for maintenance
Next days: The remaining day for maintenance
Last date: The last maintenance date

J1939 Values Page1:

```

J1939 VALUES ◀▶
Engine speed: 1500rpm
Oil pressure: 4.0bar
Coolant temp: 27°C
On load

```

Engine speed: Engine speed via J1939
Oil pressure: Oil pressure via J1939
Coolant temp: Coolant temperature via J1939

J1939 Values Page2:

```

J1939 VALUES ◀▶
Fuel rate: 12.50L/h
Fuel tot.: 176L
Oil level: 97.2%
On load

```

Fuel rate: Fuel rate via J1939
Fuel tot.: Fuel total used via J1939
Oil level: Oil level via J1939

J1939 Values Page3:

```

J1939 VALUES ◀▶
Coolant level: 87.6%
Load at cur.spd: 25%
Fuel temper.: 13°C
On load

```

Coolant level: Coolant level via J1939
Load at cur.spd: Load at current speed via J1939
Fuel temper.: Fuel temperature via J1939

J1939 Values Page4:

```

J1939 VALUES ◀▶
Oil temper.: 82.00°C
Act.engine torq: 75%
Boost press.: 2.8bar
On load

```

Oil temper.: Oil temperature via J1939
Act.engine torq: Actual engine torque via J1939
Boost press.: Boost pressure via J1939

J1939 Values Page5:

```

J1939 VALUES ◀▶
Int.man.temp.: 45°C
Pedal position: 50.0%
W.Hour_Min: 2_57
On load

```

Int.man.temp.: Intake manifold temperature via J1939
Pedal position: Accelerator pedal position via J1939
W.Hour_Min: Working hour and minute via J1939

J1939 DM1 (Active) Faults Page:

```

J1939 DM1 FAULTS1 ◀▶
Spn:110
Fmi:0          Oc:1
Coolant Temper.sensor
Value too high

```

Spn: Suspect parameter number (e.g. SPN = 110 corresponds to coolant temperature sensor)
Fmi: Failure mode identifier (e.g. FMI = 0 means value too high)
Oc: Occurrence count (if OC = 0, no alarm is present)
The first 10 active alarm messages (Active Diagnostic Trouble Codes - DM1) with SPN, FMI, and OC are displayed). If more than one active fault condition is present, all of them is displayed sequentially by pressing Next and Previous buttons.

Input & Output Status Page:

```

INPUT & OUTPUT ◀▶
           1  4  5  8
Inputs :   0000 000X
Outputs:   0000 0000
On load

```

Inputs: Input status information. If an input is active, related digit is displayed as "1" else it is displayed as "0".
1: Conf. in-1, **2:** Conf. in-2, **3:** Conf. in-3, **4:** Conf. in-4, **5:** Conf. in-5, **6:** Conf. in-6, **7:** Conf. in-7, **8:** Not available.
Outputs: Output status information. If an output is active, related digit is displayed as "1" else it is displayed as "0".
1: Conf. out-1, **2:** Conf. out-2, **3:** Conf. out-3, **4:** Conf. out-4, **5:** Conf. out-5, **6:** Conf. out-6, **7:** Generator contactor, **8:** Mains contactor.

Exp. Input & Output Status Page:

```

EXP. INPUT & OUTPUT ◀▶
           1  4  5  8
Inputs :   0000 0000
Outputs:   0000 0000
On load

```

Inputs: Exp. input status information. If an input is active, related digit is displayed as "1" else it is displayed as "0".
1: Exp. conf. in-1, **2:** Exp. conf. in-2, **3:** Exp. conf. in-3, **4:** Exp. conf. in-4, **5:** Exp. conf. in-5, **6:** Exp. conf. in-6, **7:** Exp. conf. in-7, **8:** Exp. conf. in-8.
Outputs: Exp. output status information. If an output is active, related digit is displayed as "1" else it is displayed as "0".
1: Exp. conf. out-1, **2:** Exp. conf. out-2, **3:** Exp. conf. out-3, **4:** Exp. conf. out-4, **5:** Exp. conf. out-5, **6:** Exp. conf. out-6, **7:** Exp. conf. out-7, **8:** Exp. conf. out-8.

GPRS Page:

```

■■■■ GPRS ◀▶
Operator Name
IP :0.0.0.0
APN:mgbs

```

Signal Quality: Signal Quality level indicator
Operator Name: Operator name
IP: Device IP value
APN: Access point name of the operator

GPS Page:

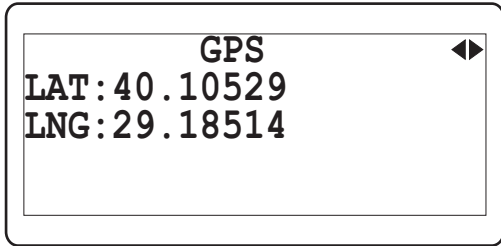

LAT: Latitude value of device's position
LNG: Longitude value of device's position

Date & Time Page:

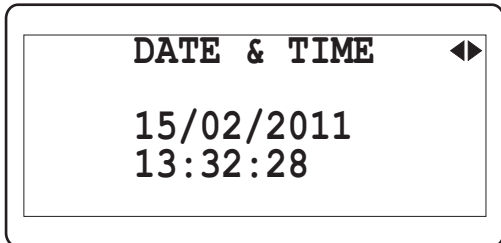

Date: Day, Month, Year.
Time: Hour, minute, second.

GenSet Page: (This page is only available at TRANS-AMF.TR device)

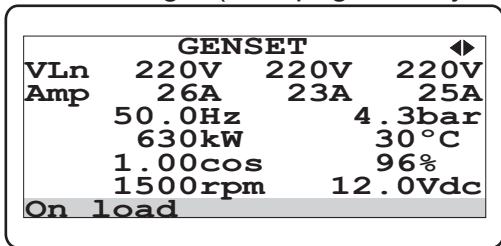

VLn: Generator voltage L1-N, L2-N and L3-N
Amp: Generator current L1, L2 and L3
Hz: Generator frequency
bar: Oil pressure sender input value
kW: Generator total active power
°C: Coolant temperature sender input value
cos: Generator power factor average
%: Configurable Analog Input-1 value
rpm: Engine speed
Vdc: Battery supply voltage

Synchronoscope Page:

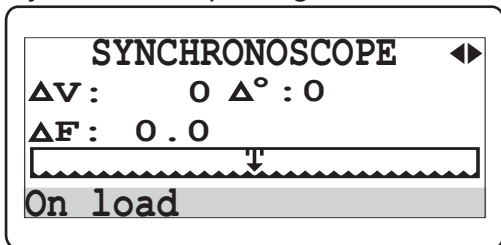

This page is for observing level differences between generator and mains voltage, frequency and phase angle. When an uninterrupted transfer is in progress, synchronoscope page will be shown automatically.

Warning & Alarm display pages on the LCD display;

Warning & Alarm Page:

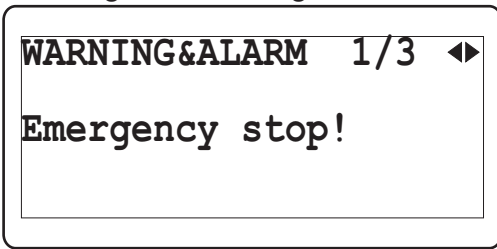

1/3: The first message of current alarms.

Emergency stop!: This message indicates that an emergency stop alarm has occurred.

Event Log display pages on the LCD display;

Event Log Page1:

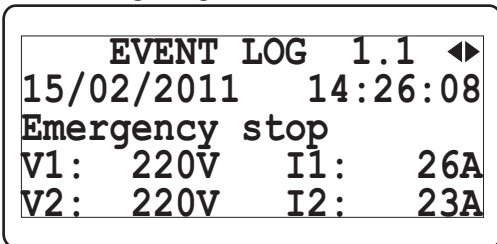

1.1: The first page of related event log

Emergency stop: This message indicates that an emergency stop alarm has occurred. (Event history: 15/02/2011 date, 14:26:08 time).

V1: Generator voltage L1-N

I1: Load Current L1

V2: Generator voltage L2-N

I2: Load Current L2

Event Log Page2:

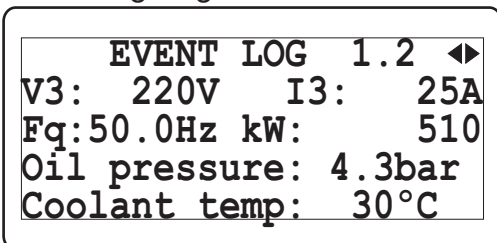

1.2: The second page of related event log

V3: Generator voltage L3-N

I3: Load Current L3

Fq: Generator frequency

kW: Generator total active power

Oil oressure: Oil pressure sender input value

Coolant temp: Coolant temperature sender input value

Event Log Page3:

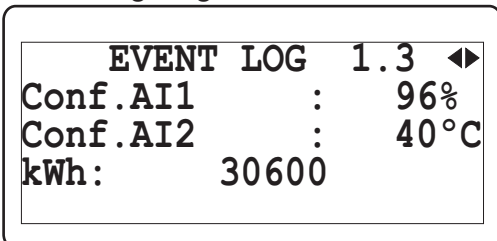

1.3: The last page of related event log

Conf. AI1: Configurable Analog Input-1 value

Conf. AI2: Configurable Analog Input-2 value

kWh: Generator active energy

Events (from 1 to 500) can be displayed sequentially with the Next and Previous buttons.

Example-1: Displaying all Data display pages.

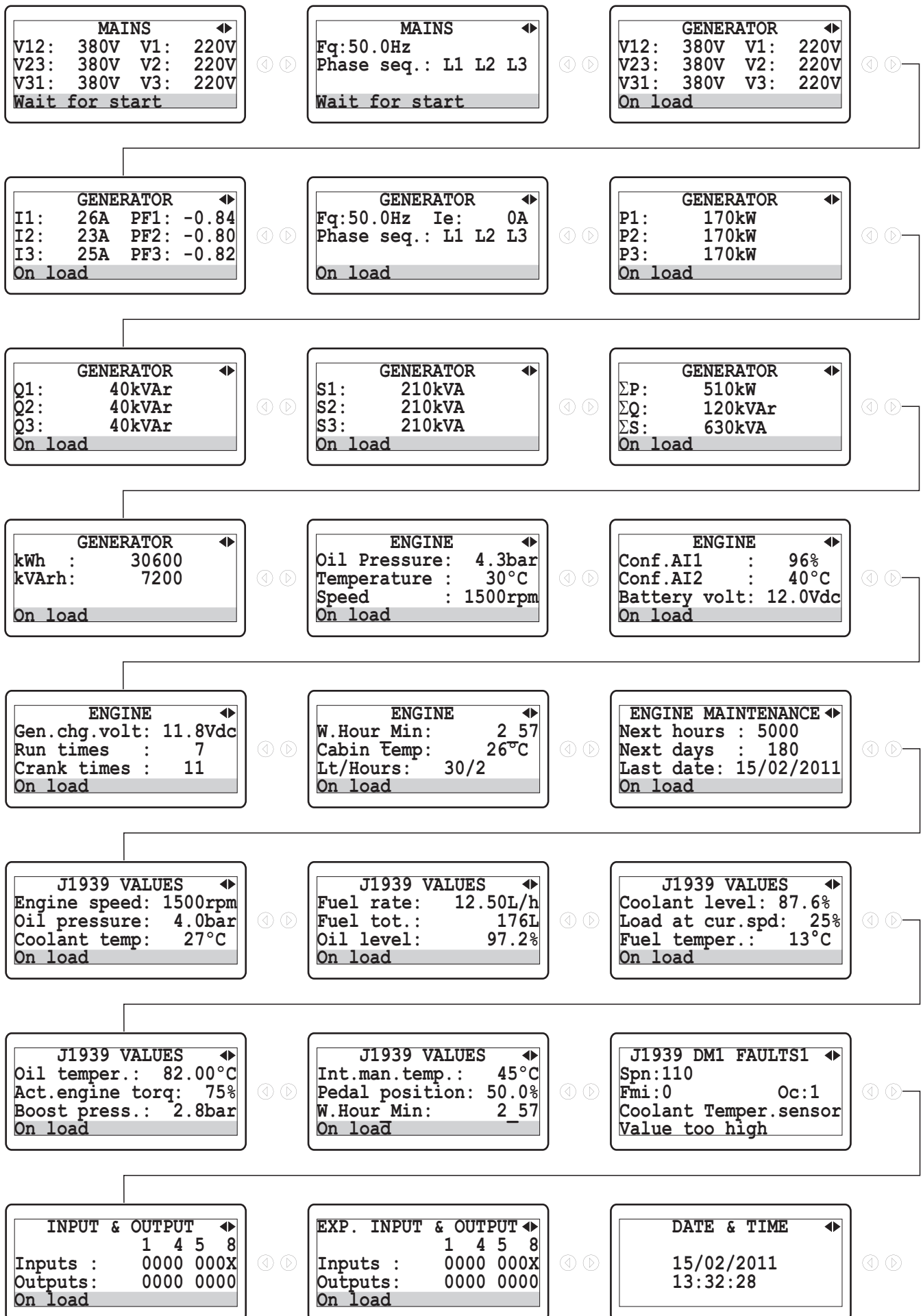

Example-2: Displaying all Warning&Alarm display pages

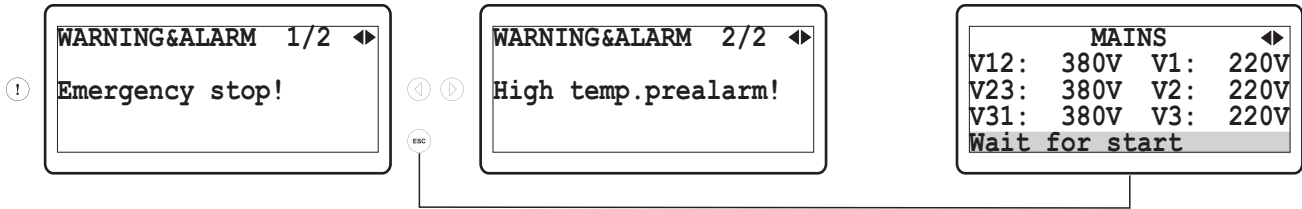

Example-3: Displaying all Event Log display pages

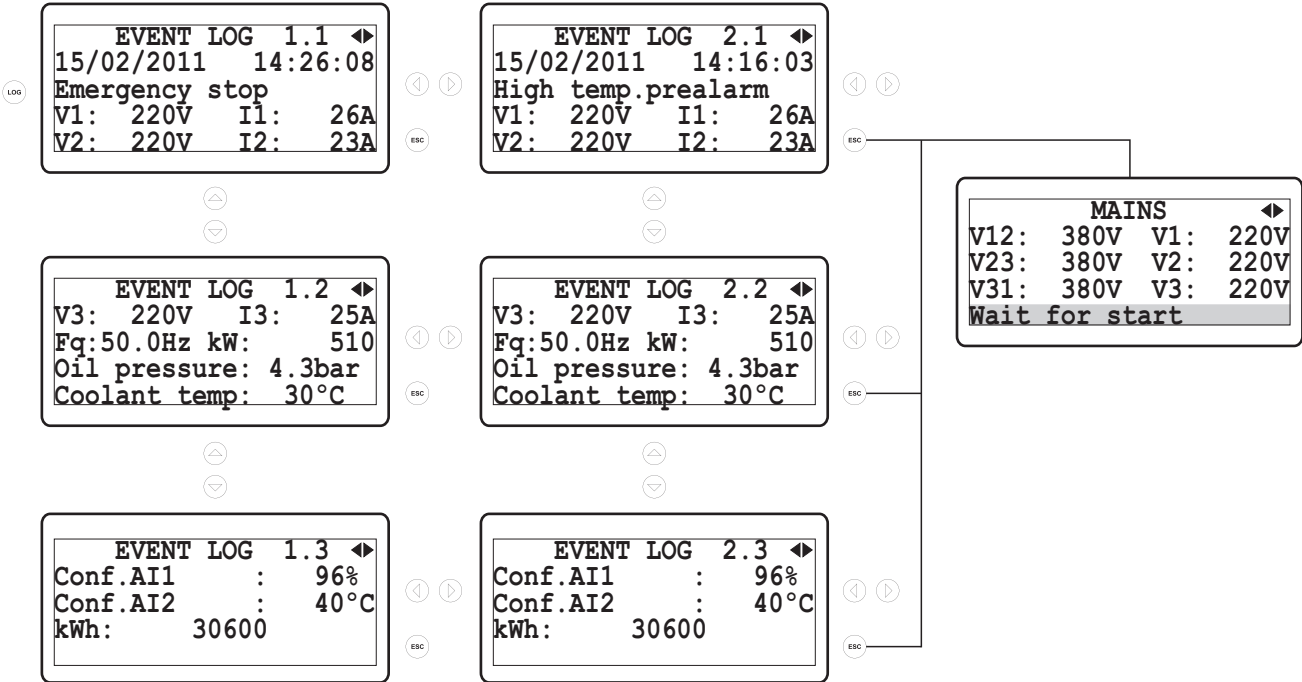

LCD display language selection

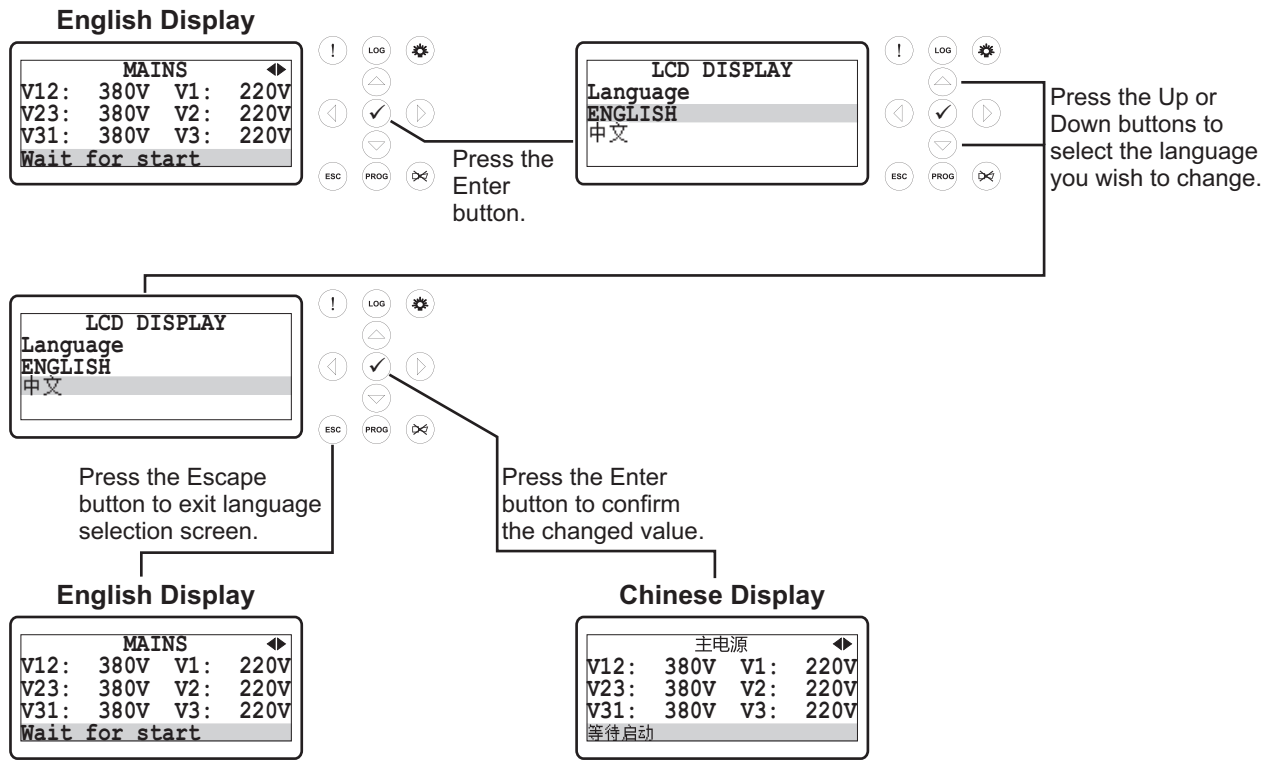

3.2 Accessing To The Operator Parameters

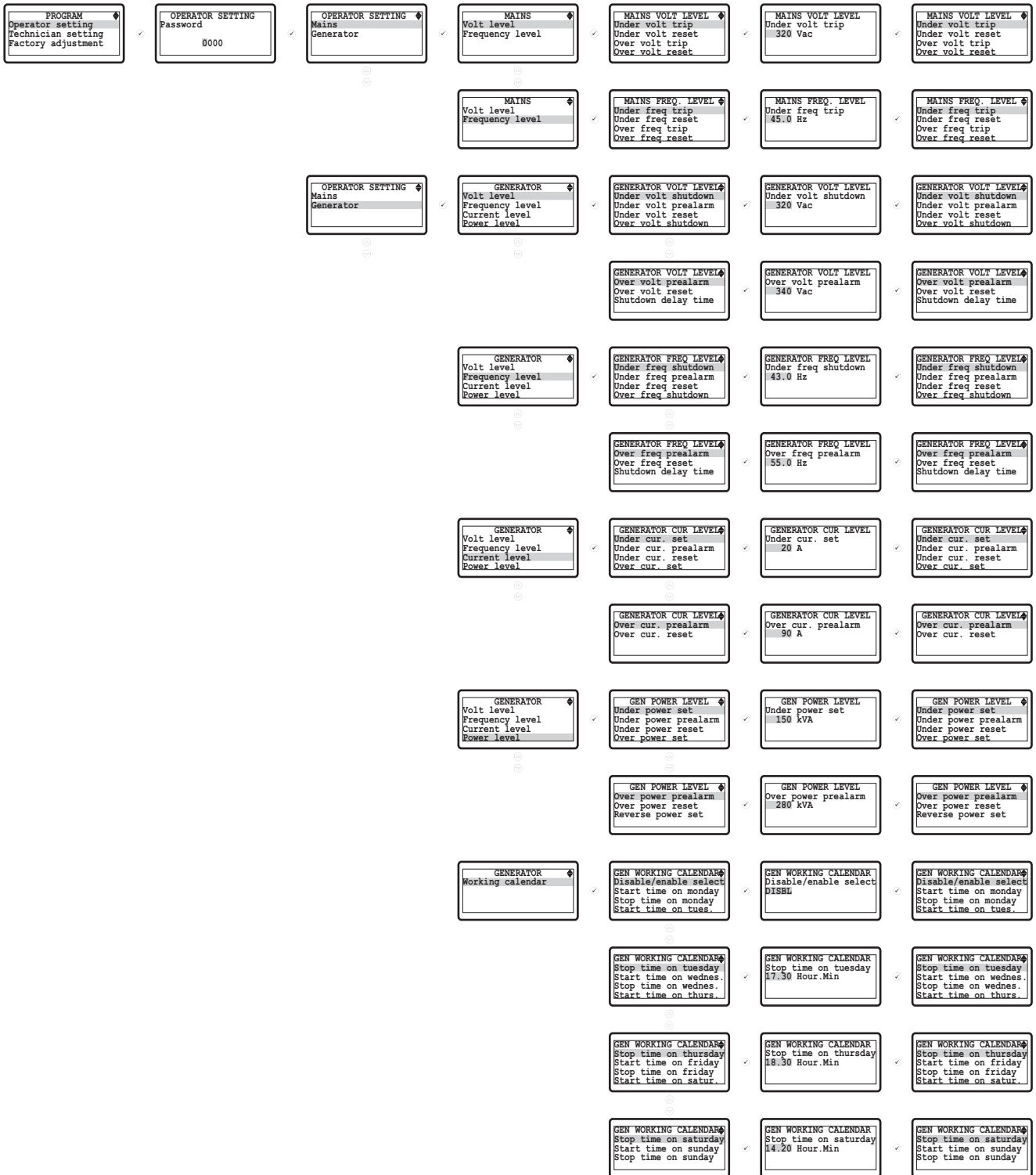

3.3 Accessing To The Technician Parameters

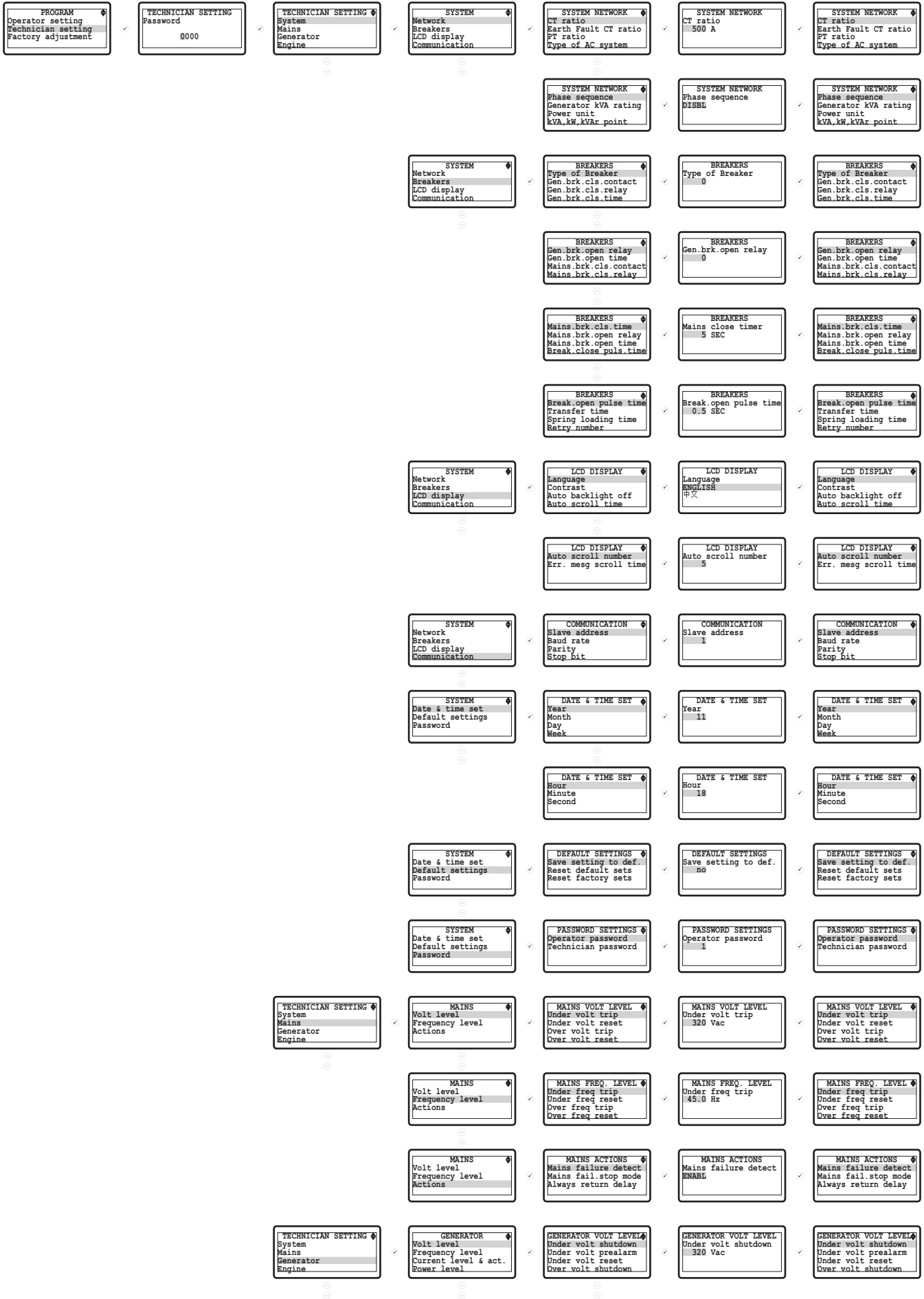

		GENERATOR VOLT LEVEL Over volt prealarm Over volt reset Shutdown delay time	GENERATOR VOLT LEVEL Over volt prealarm 340 Vac	GENERATOR VOLT LEVEL Over volt prealarm Over volt reset Shutdown delay time
GENERATOR Voltage level Frequency level Current level & act. Power level		GENERATOR FREQ LEVEL Nominal frequency Under freq shutdown Under freq prealarm Under freq reset	GENERATOR FREQ LEVEL Nominal frequency 50.0 Hz	GENERATOR FREQ LEVEL Nominal frequency Under freq shutdown Under freq prealarm Under freq reset
		GENERATOR FREQ LEVEL Over freq shutdown Over freq prealarm Over freq reset Shutdown delay time	GENERATOR FREQ LEVEL Over freq shutdown 58.0 Hz	GENERATOR FREQ LEVEL Over freq shutdown Over freq prealarm Over freq reset Shutdown delay time
GENERATOR Voltage level Frequency level Current level & act. Power level		GEN CUR LEVEL & ACT Under cur. set Under cur. prealarm Under cur. reset Under cur. act.	GEN CUR LEVEL & ACT Under cur. set 20 A	GEN CUR LEVEL & ACT Under cur. set Under cur. prealarm Under cur. reset Under cur. act.
		GEN CUR LEVEL & ACT Under act. delay time Over cur. set Over cur. prealarm Over cur. reset	GEN CUR LEVEL & ACT Under act. delay time 2 SEC	GEN CUR LEVEL & ACT Under act. delay time Over cur. set Over cur. prealarm Over cur. reset
		GEN CUR LEVEL & ACT Over cur. act. Over act. delay time Short circuit cur. Earth fault cur.	GEN CUR LEVEL & ACT Over cur. act. DISBL	GEN CUR LEVEL & ACT Over cur. act. Over act. delay time Short circuit cur. Earth fault cur.
		GEN CUR LEVEL & ACT Earth fault cur. act. E.F. act. delay time Unbalance load set Unbalance load act.	GEN CUR LEVEL & ACT Earth fault cur. act. DISBL	GEN CUR LEVEL & ACT Earth fault cur. act. E.F. act. delay time Unbalance load set Unbalance load act.
		GEN CUR LEVEL & ACT Unbalance act. delay	GEN CUR LEVEL & ACT Unbalance act. delay 2 SEC	GEN CUR LEVEL & ACT Unbalance act. delay
GENERATOR Voltage level Frequency level Current level & act. Power level		GEN POWER LEVEL Under power set Under power prealarm Under power reset Under power act.	GEN POWER LEVEL Under power shutdown 150 kVA	GEN POWER LEVEL Under power prealarm Under power reset Under power act.
		GEN POWER LEVEL Under act. delay time Over power set Over power prealarm Over power reset	GEN POWER LEVEL Under act. delay time 2 SEC	GEN POWER LEVEL Under act. delay time Over power set Over power prealarm Over power reset
		GEN POWER LEVEL Over power act. Over act. delay time Reverse power set Reverse power act.	GEN POWER LEVEL Over power act. DISBL	GEN POWER LEVEL Over power act. Over act. delay time Reverse power set Reverse power act.
		GEN POWER LEVEL Rv.pow.act.delay time	GEN POWER LEVEL Rv.pow.act.delay time 2 SEC	GEN POWER LEVEL Rv.pow.act.delay time
GENERATOR Working calendar General		GEN WORKING CALENDAR Disable/enable select Start time on monday Stop time on monday Start time on tues.	GEN WORKING CALENDAR Disable/enable select DISBL	GEN WORKING CALENDAR Disable/enable select Start time on monday Stop time on monday Start time on tues.
		GEN WORKING CALENDAR Stop time on tuesday Start time on wednes. Stop time on wednes. Start time on thurs.	GEN WORKING CALENDAR Stop time on tuesday 17.30 Hour.Min	GEN WORKING CALENDAR Stop time on tuesday Start time on wednes. Stop time on wednes. Start time on thurs.
		GEN WORKING CALENDAR Stop time on thursday Start time on friday Stop time on friday Start time on satur.	GEN WORKING CALENDAR Stop time on thursday 18.30 Hour.Min	GEN WORKING CALENDAR Stop time on thursday Start time on friday Stop time on friday Start time on satur.
		GEN WORKING CALENDAR Stop time on saturday Start time on sunday Stop time on sunday	GEN WORKING CALENDAR Stop time on saturday 14.20 Hour.Min	GEN WORKING CALENDAR Stop time on saturday Start time on sunday Stop time on sunday
GENERATOR Working calendar General		GENERATOR GENERAL Sens.option gen.freq Sens.opt.pickup&Flywh All warning are latch	GENERATOR GENERAL Sens.option gen.freq DISBL	GENERATOR GENERAL Sens.option gen.freq Sens.opt.pickup&Flywh All warning are latch
TECHNICIAN SETTING System Mains Generator Engine	ENGINE Starting options Crank disconnect Speed settings Plant battery	ENGINE START OPTIONS Horn prior start No. of start attempt Cranking time Crank rest time	ENGINE START OPTIONS Horn prior start DISBL	ENGINE START OPTIONS Horn prior start No. of start attempt Cranking time Crank rest time

	ENGINE START OPTIONS Pickup fail delay	ENGINE START OPTIONS Pickup fail delay 1.0 sec	ENGINE START OPTIONS Pickup fail delay
ENGINE Starting options Crank disconnect Speed settings Plant battery	ENG. CRANK DISCONNECT Generator frequency Engine speed Generator volt Alt. Charge volt	ENG. CRANK DISCONNECT Generator frequency 30.0 Hz	ENG. CRANK DISCONNECT Generator frequency Engine speed Generator volt Alt. Charge volt
	ENG. CRANK DISCONNECT Oil pressure	ENG. CRANK DISCONNECT Oil pressure DISBL	ENG. CRANK DISCONNECT Oil pressure
ENGINE Starting options Crank disconnect Speed settings Plant battery	ENGINE SPEED SETS Nominal speed Under speed shutdown Under speed prealarm Under speed reset	ENGINE SPEED SETS Nominal speed 1500 RPM	ENGINE SPEED SETS Nominal speed Under speed shutdown Under speed prealarm Under speed reset
	ENGINE SPEED SETS Over speed shutdown Over speed prealarm Over speed reset Shutdown delay time	ENGINE SPEED SETS Over speed shutdown DISBL	ENGINE SPEED SETS Over speed shutdown Over speed prealarm Over speed reset Shutdown delay time
ENGINE Starting options Crank disconnect Speed settings Plant battery	ENGINE PLANT BATTERY Under volt Under volt reset Under volt delay Over volt	ENGINE PLANT BATTERY Under volt 10.0 Vdc	ENGINE PLANT BATTERY Under volt Under volt reset Under volt delay Over volt
	ENGINE PLANT BATTERY Over volt reset Over volt delay Alt. chg. warning	ENGINE PLANT BATTERY Over volt reset 29.5 Vdc	ENGINE PLANT BATTERY Over volt reset Over volt delay Alt. chg. warning
ENGINE CanBus ECU CanBus error set Maintenance Load test	CANBUS ECU Baud rate J1939 ECU type Device address Engine cont. address	CANBUS ECU Baud rate 4	CANBUS ECU Baud rate J1939 ECU type Device address Engine cont. address
	CANBUS ECU ECU remote control Speed control enable Oil Pres cont. enab Temp_control enable	CANBUS ECU ECU remote control DISBL	CANBUS ECU ECU remote control Speed control enable Oil Pres cont. enab Temp_control enable
	CANBUS ECU Speed set point Speed correction	CANBUS ECU Speed set point 1500 RPM	CANBUS ECU Speed set point Speed correction
ENGINE CanBus ECU CanBus error set Maintenance Load test	CANBUS ERROR SET CAN fault actions CAN fault activation CAN fault delay Amber warn.actions	CANBUS ERROR SET CAN fault actions DISBL	CANBUS ERROR SET CAN fault actions CAN fault activation CAN fault delay Amber warn.actions
	CANBUS ERROR SET Amber warn.activation Red stop actions Red stop activation	CANBUS ERROR SET Amber warn.activation 2	CANBUS ERROR SET Amber warn.activation Red stop actions Red stop activation
	CANBUS ERROR SET Red stop delay	CANBUS ERROR SET Red stop delay 2 SEC	CANBUS ERROR SET Red stop delay
ENGINE CanBus ECU CanBus error set Maintenance Load test	ENGINE MAINTENANCE Running hour interval Maint. date interval Eng. stop when maint Eng. running hour (lsb)	ENGINE MAINTENANCE Running hour interval 5000 HOUR	ENGINE MAINTENANCE Running hour interval Maint. date interval Eng. stop when maint Eng. running hour (lsb)
	ENGINE MAINTENANCE Eng. running hour Eng. running hour (msb) Maintenance okay	ENGINE MAINTENANCE Eng. running hour 0	ENGINE MAINTENANCE Eng. running hour (msb) Maintenance okay
ENGINE CanBus ECU CanBus error set Maintenance Load test	LOAD TEST Disable/enable select	LOAD TEST Disable/enable select DISBL	LOAD TEST Disable/enable select
ENGINE Exercise General	EXERCISE Disable/enable select Start time on monday Stop time on monday Start time on tues.	EXERCISE Disable/enable select DISBL	EXERCISE Disable/enable select Start time on monday Stop time on monday Start time on tues.
	EXERCISE Stop time on Tuesday Start time on wednes. Stop time on wednes. Start time on thurs.	EXERCISE Stop time on Tuesday 0:00 Hour.Min	EXERCISE Stop time on Tuesday Start time on wednes. Stop time on wednes. Start time on thurs.

		EXERCISE Stop time on Thursday Start time on Friday Stop time on Friday Start time on Saturday Start time on Saturday	EXERCISE Stop time on Thursday 0.00 Hour.Min	EXERCISE Stop time on Thursday Start time on Friday Stop time on Friday Start time on Saturday
		EXERCISE Stop time on Saturday Start time on Sunday Stop time on Sunday	EXERCISE Stop time on Saturday 0.00 Hour.Min	EXERCISE Stop time on Saturday Start time on Sunday Stop time on Sunday
	ENGINE Exercise General	ENGINE GENERAL Fuel selection Stop solenoid time Ignition delay Gas valve delay	ENGINE GENERAL Fuel selection 1=DIESEL	ENGINE GENERAL Fuel selection Stop solenoid time Ignition delay Gas valve delay
		ENGINE GENERAL Min.of ignition speed Choke time	ENGINE GENERAL Min.of ignition speed 200 RPM	ENGINE GENERAL Min.of ignition speed Choke time
TECHNICIAN SETTING Inputs Outputs Timers Expansion modules	INPUTS Sender inputs Sender linearisations Conf. input-1 Conf. input-2	SENDER INPUTS Oil pressure unit Oil press. input type Oil pressure prealarm Oil pressure reset	SENDER INPUTS Oil pressure unit Bar	SENDER INPUTS Oil pressure unit Oil press. input type Oil pressure prealarm Oil pressure reset
		SENDER INPUTS Oil pressure shutdown Temperature unit Temp. input type High temp. prealarm	SENDER INPUTS Oil press. shutdown 1.0 Bar	SENDER INPUTS Oil pressure shutdown Temperature unit Temp. input type High temp. prealarm
		SENDER INPUTS High temp. reset High temp. shutdown Low temp. Warning Heater control ON	SENDER INPUTS High temp. reset 88 °C	SENDER INPUTS High temp. reset High temp. shutdown Low temp. Warning Heater control ON
		SENDER INPUTS Heater control OFF Water pump on time Water pump off time Conf. AI1 unit	SENDER INPUTS Heater control OFF 45 °C	SENDER INPUTS Heater control OFF Water pump on time Water pump off time Conf. AI1 unit
		SENDER INPUTS Conf. AI1 type Conf. AI1 low prealarm Conf. AI1 low reset Conf. AI1 low shutdown	SENDER INPUTS Conf. AI1 type 0=NOT USED	SENDER INPUTS Conf. AI1 type Conf. AI1 low prealarm Conf. AI1 low reset Conf. AI1 low shutdown
		SENDER INPUTS Conf. AI1 high prealarm Conf. AI1 high reset Conf. AI1 high shutdown Conf. AI1 control ON	SENDER INPUTS Conf. AI1 high prealarm DISEL	SENDER INPUTS Conf. AI1 high prealarm Conf. AI1 high reset Conf. AI1 high shutdown Conf. AI1 control ON
		SENDER INPUTS Conf. AI1 control OFF Conf. AI2 unit Conf. AI2 type Conf. AI2 low prealarm	SENDER INPUTS Conf. AI1 control OFF 75 %	SENDER INPUTS Conf. AI1 control OFF Conf. AI2 unit Conf. AI2 type Conf. AI2 low prealarm
		SENDER INPUTS Conf. AI2 low reset Conf. AI2 low shutdown Conf. AI2 high prealarm Conf. AI2 high reset	SENDER INPUTS Conf. AI2 low reset 60 °C	SENDER INPUTS Conf. AI2 low reset Conf. AI2 low shutdown Conf. AI2 high prealarm Conf. AI2 high reset
		SENDER INPUTS Conf. AI2 high shutdown Conf. AI2 control ON Conf. AI2 control OFF	SENDER INPUTS Conf. AI2 high shutdown DISEL	SENDER INPUTS Conf. AI2 high shutdown Conf. AI2 control ON Conf. AI2 control OFF
	INPUTS Sender inputs Sender linearisations Conf. input-1 Conf. input-2	SENDER LINEARISATION Oil pressure sender 1 Oil pressure sender 2 Oil pressure sender 2	SENDER LINEARISATION Oil pressure sender 1 10 R	SENDER LINEARISATION Oil pressure sender 1 Oil pressure sender 2 Oil pressure sender 2
		SENDER LINEARISATION Oil pressure sender 3 Oil pressure sender 4 Oil pressure sender 4	SENDER LINEARISATION Oil pressure sender 3 62 R	SENDER LINEARISATION Oil pressure sender 3 Oil pressure sender 4 Oil pressure sender 4
		SENDER LINEARISATION Oil pressure sender 5 Oil pressure sender 6 Oil pressure sender 6	SENDER LINEARISATION Oil pressure sender 5 111 R	SENDER LINEARISATION Oil pressure sender 5 Oil pressure sender 6 Oil pressure sender 6
		SENDER LINEARISATION Oil pressure sender 7 Oil pressure sender 8 Oil pressure sender 8	SENDER LINEARISATION Oil pressure sender 7 156 R	SENDER LINEARISATION Oil pressure sender 7 Oil pressure sender 8 Oil pressure sender 8
		SENDER LINEARISATION Oil pressure sender 9 Oil pressure sender 10 Oil pressure sender 10	SENDER LINEARISATION Oil pressure sender 9 205 R	SENDER LINEARISATION Oil pressure sender 9 Oil pressure sender 10 Oil pressure sender 10

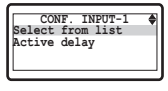
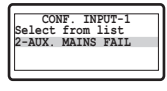
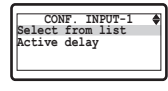
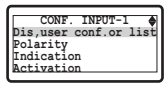
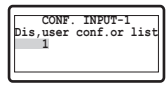
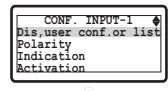
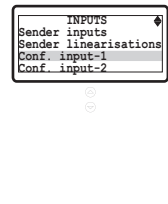
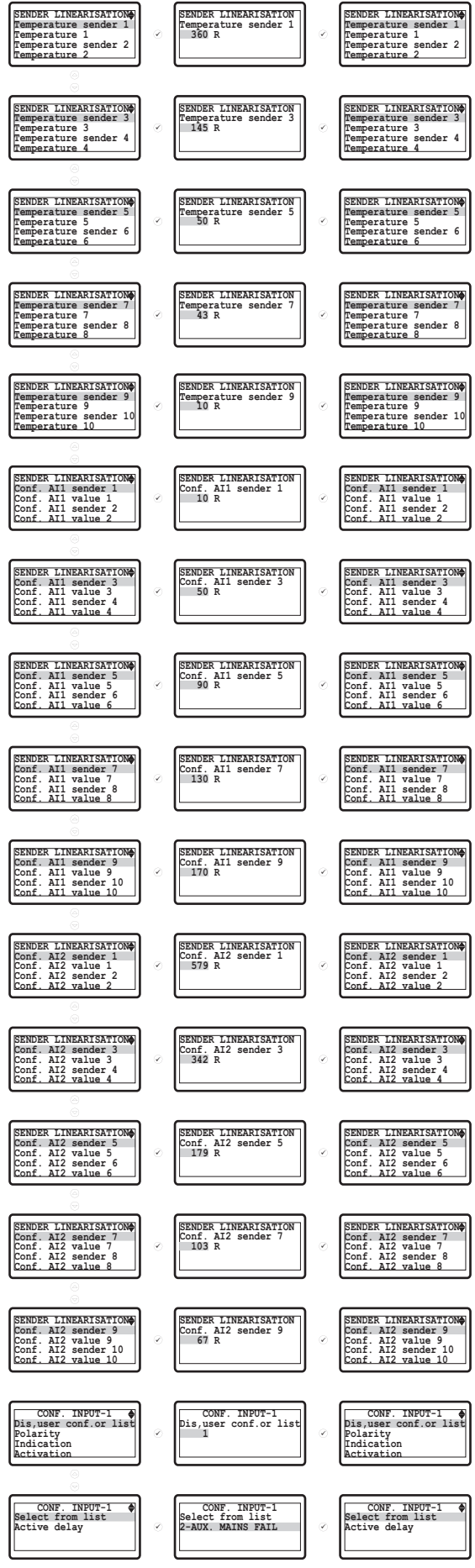

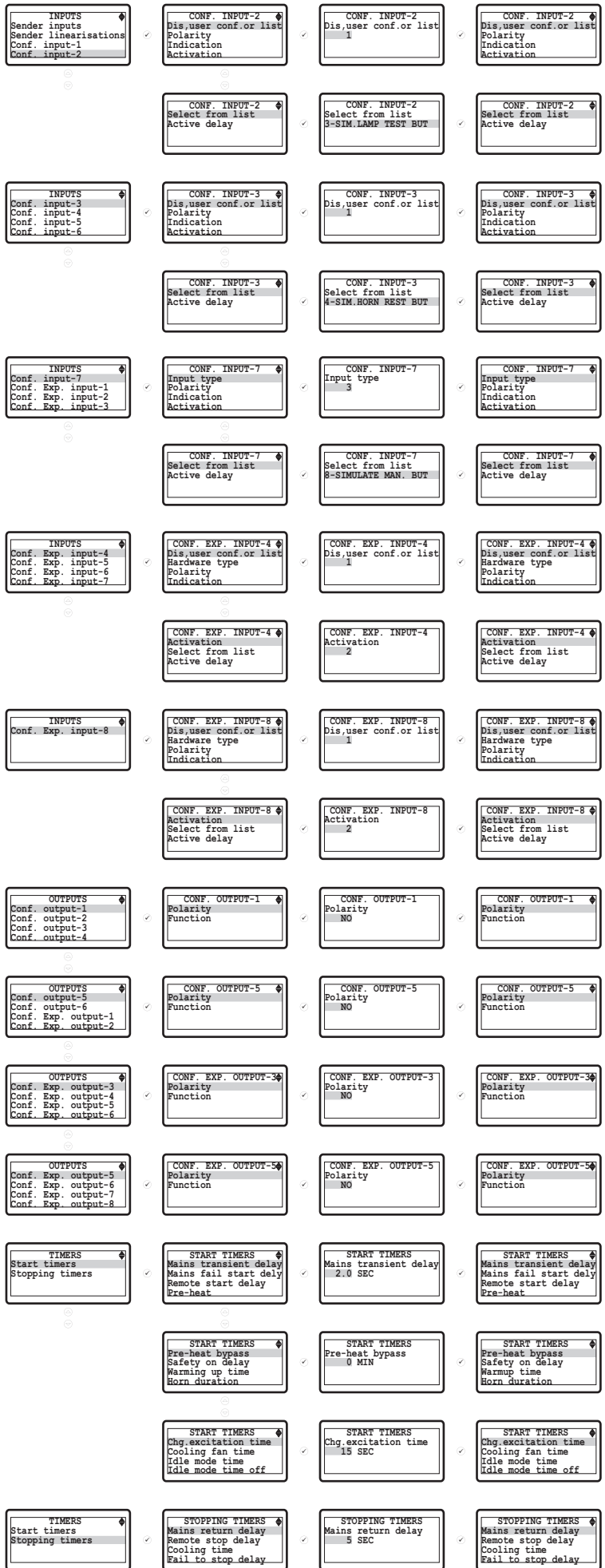

TECHNICIAN SETTING Inputs Outputs Timers Expansion modules	EXPANSION MODULES IO (1-8) Dial-up & Ethernet GPRS Dual set	GPRS MODULE Disable/enable select	IO (1-8) MODULE Disable/enable select DISBL	IO (1-8) MODULE Disable/enable select
	EXPANSION MODULES IO (1-8) Dial-up & Ethernet GPRS Dual set	DIAL-UP & ETHERNET Disable/enable select Call back selection	DIAL-UP & ETHERNET Disable/enable select DISBL	DIAL-UP & ETHERNET Disable/enable select Call back selection
	EXPANSION MODULES IO (1-8) Dial-up & Ethernet GPRS Dual set	GPRS MODULE Disable/enable select Call back selection Cell inf refresh rate Location data	GPRS MODULE Disable/enable select 1=GPRS SERVER	GPRS MODULE Disable/enable select Call back selection Cell inf refresh rate Location data
	EXPANSION MODULES IO (1-8) Dial-up & Ethernet GPRS Dual set	DUAL SET MODULE Disable/enable select Node ID Working period Early start time	DUAL SET MODULE Disable/enable select DISBL	DUAL SET MODULE Disable/enable select Node ID Working period Early start time
	EXPANSION MODULES IO (1-8) Dial-up & Ethernet GPRS Dual set	DUAL SET MODULE Remote priority select	DUAL SET MODULE Remote priority select DISBL	DUAL SET MODULE Remote priority select
	EXPANSION MODULES Web Server GPRS Web	WEB SERVER MODULE Disable/enable select	WEB SERVER MODULE Disable/enable select DISBL	WEB SERVER MODULE Disable/enable select
TECHNICIAN SETTING User adjustment	EXPANSION MODULES Web Server GPRS Web	GPRS WEB MODULE Disable/enable select	GPRS WEB MODULE Disable/enable select DISBL	GPRS WEB MODULE Disable/enable select
	USER ADJUSTMENT Mains voltage offset Gen. voltage offset Current offset Batterychg_gen.vol	MAINS VOLTAGE OFFSET Mains V1 offset Mains V2 offset Mains V3 offset	MAINS VOLTAGE OFFSET Mains V1 offset 0 Vac	MAINS VOLTAGE OFFSET Mains V1 offset Mains V2 offset Mains V3 offset
	USER ADJUSTMENT Mains voltage offset Gen. voltage offset Current offset Batterychg_gen.vol	GEN. VOLTAGE OFFSET Gen. V1 offset Gen. V2 offset Gen. V3 offset	GEN. VOLTAGE OFFSET Gen. V1 offset 0 Vac	GEN. VOLTAGE OFFSET Gen. V1 offset Gen. V2 offset Gen. V3 offset
	USER ADJUSTMENT Mains voltage offset Gen. voltage offset Current offset Batterychg_gen.vol	CURRENT OFFSET Current I1 offset Current I2 offset Current I3 offset E/F Current offset	CURRENT OFFSET Current I1 offset 0 A	CURRENT OFFSET Current I1 offset Current I2 offset Current I3 offset E/F Current offset
	USER ADJUSTMENT Mains voltage offset Gen. voltage offset Current offset Batterychg_gen.vol	BATTERYCHRG GEN.VOL Batt.volt offset Gen.chg.volt offset	BATTERYCHRG GEN.VOL Batt.volt offset 0.0 Vdc	BATTERYCHRG GEN.VOL Batt.volt offset Gen.chg.volt offset
	USER ADJUSTMENT Sender inputs offset	SENDER INPUTS OFFSET Oil pressure offset Temperature offset Conf. A11 offset Conf. A12 offset	SENDER INPUTS OFFSET Oil pressure offset 0.0 Bar	SENDER INPUTS OFFSET Oil pressure offset Temperature offset Conf. A11 offset Conf. A12 offset

3.4 Changing And Saving Parameters Values

Operation Screen

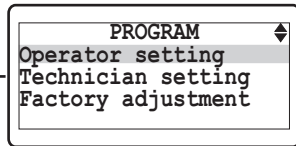
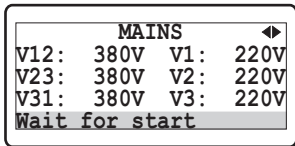

Press the Up or Down buttons to select the section you wish to view/change.

When the Prog button is pressed, the parameters section is asked for accessing to parameters.

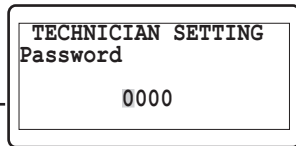
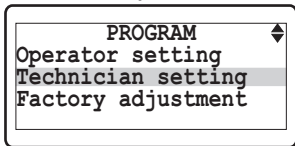

Enter password with cursor (Right, Left, Up and Down) buttons.

Press the Enter button.

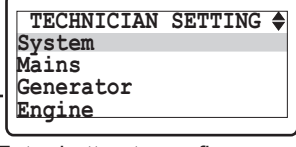
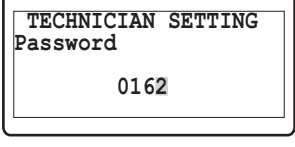

Press the Up or Down buttons to select the main parameter group you wish to view/change.

Note1: If Enter button is pressed and the technician password is zero, Password screen is ignored.

Press the Enter button to confirm password. If the password is incorrect, the unit will drop out of program mode.

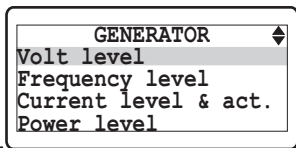
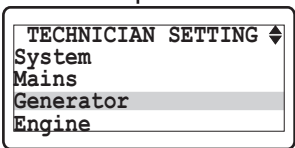

Press Enter button to access to all parameters page in currently main parameter group.

Press Enter button to access to all parameters in currently parameter page.

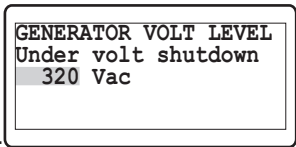
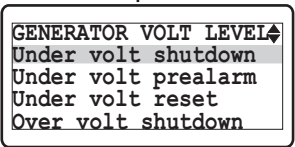

Parameter can be changed with Up and Down buttons.

Press the Enter button to view parameter value.

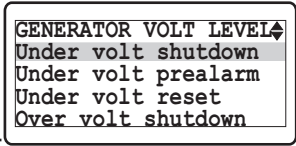
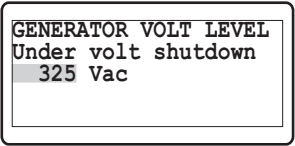

Press Enter button to confirm the changed value.

To exit from programming mode any time, press Prog button.

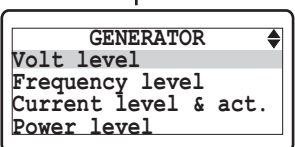

When the Escape button is pressed any time, previous page can be accessed.

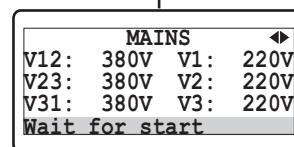

Operation Screen

4. Parameters

4.1 Operator Parameters

4.1.1 Mains

MAINS VOLT LEVEL (<i>Mains->Volt level</i>)		Min	Max	Default	Unit
Under volt trip	Mains Under Voltage	60	600	320	V \sim
Under volt reset	Mains Under Voltage Reset	60	600	340	V \sim
Over volt trip	Mains Over Voltage	60	600	440	V \sim
Over volt reset	Mains Over Voltage Reset	60	600	420	V \sim

MAINS FREQ. LEVEL (<i>Mains->Frequency level</i>)		Min	Max	Default	Unit
Under freq trip	Mains Under Frequency	20.0	75.0	45.0	Hz
Under freq reset	Mains Under Frequency Reset	20.0	75.0	48.0	Hz
Over freq trip	Mains Over Frequency	20.0	75.0	55.0	Hz
Over freq reset	Mains Over Frequency Reset	20.0	75.0	52.0	Hz

4.1.2 Generator

GENERATOR VOLT LEVEL (<i>Generator->Volt level</i>)		Min	Max	Default	Unit
Under volt shutdown	Generator Under Voltage Shutdown	60(dis)	600	320	V \sim
Under volt prealarm	Generator Under Voltage Pre-Alarm	60(dis)	600	340	V \sim
Under volt reset	Generator Under Voltage Pre-Alarm Reset	60	600	350	V \sim
Over volt shutdown	Generator Over Voltage Shutdown	60	600	440	V \sim
Over volt prealarm	Generator Over Voltage Pre-Alarm	60(dis)	600	420	V \sim
Over volt reset	Generator Over Voltage Pre-Alarm Reset	60	600	400	V \sim
Shutdown delay time	Generator Voltage Shutdown Delay Time	0.0	10.0	1.0	Sec

GENERATOR FREQ LEVEL (<i>Generator->Frequency level</i>)		Min	Max	Default	Unit
Nominal frequency	Nominal Alternator Frequency	30.0	75.0	50.0	Hz
Under freq shutdown	Generator Under Frequency Shutdown	30.0(dis)	75.0	43.0	Hz
Under freq prealarm	Generator Under Frequency Pre-Alarm	30.0(dis)	75.0	45.0	Hz
Under freq reset	Generator Under Frequency Pre-Alarm Reset	30.0	75.0	46.0	Hz
Over freq shutdown	Generator Over Frequency Shutdown	30.0(dis)	75.0	58.0	Hz
Over freq prealarm	Generator Over Frequency Pre-Alarm	30.0(dis)	75.0	55.0	Hz
Over freq reset	Generator Over Frequency Pre-Alarm Reset	30.0	75.0	54.0	Hz
Shutdown delay time	Generator Frequency Shutdown Delay Time	0.0	10.0	1.0	Sec

GENERATOR CUR LEVEL (<i>Generator->Current level</i>)		Min	Max	Default	Unit
Under cur. set	Generator Under Current Set	0	9999	1	A \sim
Under cur. prealarm	Generator Under Current Pre-Alarm	0(dis)	9999	dis	A \sim
Under cur. reset	Generator Under Current Pre-Alarm Reset	0	9999	5	A \sim
Over cur. IDMT alarm	Generator Over Current IDMT Alarm	ENABL/DISBL		DISBL	
Over cur. set	Generator Over Current Set	0	9999	9999	A \sim
Over cur. prealarm	Generator Over Current Pre-Alarm	0(dis)	9999	9990	A \sim
Over cur. reset	Generator Over Current Pre-Alarm Reset	0	9999	9980	A \sim

Note: dis = disable

GEN POWER LEVEL (Generator->Power level)		Min	Max	Default	Unit
Under power set	Generator Under Power Set	0	9999	0	kVA
Under power prealarm	Generator Under Power Pre-Alarm	0(dis)	9999	dis	kVA
Under power reset	Generator Under Power Pre-Alarm Reset	0	9999	5	kVA
Over power IDMT alarm	Generator Over Power IDMT Alarm	ENABL/DISBL		DISBL	
Over power set	Generator Over Power Set	0	9999	0	kVA
Over power prealarm	Generator Over Power Pre-Alarm	0(dis)	9999	dis	kVA
Over power reset	Generator Over Power Pre-Alarm Reset	0	9999	0	kVA
Over load step 1	Generator Over Load Step 1	0	9999	9999	KVA
Over load step 1 rest	Generator Over Load Step 1 Reset	0	9999	9999	KVA
Over load step 2	Generator Over Load Step 2	0	9999	9999	KVA
Over load step 2 rest	Generator Over Load Step 2 Reset	0	9999	9999	KVA
Reverse power set	Reverse Power Set	-9999	0	0	kW

GEN WORKING CALENDAR (Generator->Working calendar)		Min	Max	Default	Unit
Disable/enable select	Working Calendar Disable or Enable	DISBL/ENABL		DISBL	
Start time on monday	Working Calendar Work Start Time on Monday	0.00	23.59	0.00	H.Min
Stop time on monday	Working Calendar Work Stop Time on Monday	0.00	23.59	23.59	H.Min
Start time on tues.	Working Calendar Work Start Time on Tuesday	0.00	23.59	0.00	H.Min
Stop time on tuesday	Working Calendar Work Stop Time on Tuesday	0.00	23.59	23.59	H.Min
Start time on wednes.	Working Calendar Work Start Time on Wednesday	0.00	23.59	0.00	H.Min
Stop time on wednes.	Working Calendar Work Stop Time on Wednesday	0.00	23.59	23.59	H.Min
Start time on thurs.	Working Calendar Work Start Time on Thursday	0.00	23.59	0.00	H.Min
Stop time on thursday	Working Calendar Work Stop Time on Thursday	0.00	23.59	23.59	H.Min
Start time on friday	Working Calendar Work Start Time on Friday	0.00	23.59	0.00	H.Min
Stop time on friday	Working Calendar Work Stop Time on Friday	0.00	23.59	23.59	H.Min
Start time on satur.	Working Calendar Work Start Time on Saturday	0.00	23.59	0.00	H.Min
Stop time on saturday	Working Calendar Work Stop Time on Saturday	0.00	23.59	23.59	H.Min
Start time on sunday	Working Calendar Work Start Time on Sunday	0.00	23.59	0.00	H.Min
Stop time on sunday	Working Calendar Work Stop Time on Sunday	0.00	23.59	23.59	H.Min

Calendar Disable or Enable

DISABLE: The unit will not monitor the working calendar parameters. If the mains supply go out side of limits, the unit will initiate automatic mains failure sequence.

ENABLE: The unit will monitor the working calendar parameters. If the mains supply go out side of limits, the unit will initiate automatic mains failure sequence only within the set "Start and Stop time parameters". Otherwise, the unit will not initiate automatic mains failure sequence and the "Auto" led will blink.

Note-1: If the "Start time parameter" of any day is set to "0.00" and the "Stop time parameter" is set to "23.59", the unit will initiate automatic mains failure sequence when the mains supply go out side of limits within that day.

Note-2: If the "Start and Stop time parameters" of any day are set the same, the unit will not initiate automatic mains failure sequence when the mains supply go out side of limits within that day.

4.2 Technician Parameters

4.2.1 System

SYSTEM NETWORK (<i>System->Network</i>)		Min	Max	Default	Unit
CT ratio	Current Transformer Ratio	1	9999	100	
Earth fault CT ratio	Earth Fault Current Transformer Ratio	1	9999	100	
PT ratio	Voltage Transformer Ratio	1	100	1	
Type of AC system	Select AC system; 0- 1 Phase 2 Wire 1- 3 Phase 4 Wire 2- 2 Phase 3 Wire L1-L2 3- 2 Phase 3 Wire L1-L3	0	3	1	
Phase sequence	Generator Phase Sequence (dis, L123 or L321)	DISBL, L123, L321		DISBL	
Generator kVA rating	Generator kVA rating set	0	9999	300	kVA
Power unit	Power unit	kVA/kW		kVA	
kVA,kW,kVAr point	kVA, kW, kVAr point position; 0-> 0 1-> 0.0 2-> 0.00 3-> 0.000	0	3	0	
CT location	Current Transformer Location; 0-> Generator 1-> Load	0	1	0	
Power on mode	Power On Mode Selection	0-LAST MODE 1-AUTO MODE 2-TEST MODE 3-MANUAL MODE 4-STOP MODE		0-LAST MODE	

CT ratio

Load current transformer's transfer ratio(Primary current/Secondary current) value must be entered to this parameter.

Example:

If Current Transformer Primary=500A and Current Transformer Secondary=5A, Current Transformer Ratio should be entered CT Primary/CT Secondary=100.

Earth fault CT ratio

Earth current transformer's transfer ratio value must be entered to this parameter.

PT ratio

Defines the scaling factor applied to voltage readout and associated fault conditions. This PT ratio is for additional voltage transformers mounted the unit.

Type of AC System

This parameter is used to detail the type of AC system to which the unit is connected: 1 phase 2 wire, 3 phase 4 wire, 2 phase 3 wire L1-L2, 2 phase 3 wire L1-L3.

Phase Sequence

DISABLE: the mains and generator phase sequence checking disabled.

L123 or L321: if the mains phase sequence is faulty, the "Mains phase sequence wrong" warning is given and the mains contactor is deenergized. If the generator phase sequence is faulty, the "Generator phase sequence wrong" warning is given and the generator is stopped.

CT location

0-Generator: The CTs are located to the generator side, so will show only generator load.

1-Load: The CTs are located to the load side, so will show generator or mains load provided by supply.

BREAKERS (System->Breakers)		Min	Max	Default	Unit
Type of Breaker	Hardware Breaker Selection	0	2	0	
Gen.brk.cls.contact	Gen Close Breaker Contact Type	NO / NC		0	
Gen.brk.cls.relay	Gen Close Breaker Relay Type	NOR / PULS		0	
Gen.brk.cls.time	Gen Close Timer	1	250	5	Sec
Gen.brk.open relay	Gen Open Breaker Relay Type	NOR / PULS		0	
Gen.brk.open time	Gen Open Timer	1	250	5	Sec
Mains.brk.cls.contact	Mains Close Breaker Contact Type	NO / NC		0	
Mains.brk.cls.relay	Mains Close Breaker Relay Type	NOR / PULS		0	
Mains.brk.cls.time	Mains Close Timer	1	250	5	Sec
Mains.brk.open relay	Mains Open Breaker Relay Type	NOR / PULS		0	
Mains.brk.open time	Mains Open Timer	1	250	5	Sec
Break.close puls.time	Breaker Close Pulse Time	0.0	10.0	0.5	Sec
Break.open pulse time	Breaker Open Pulse Time	0.0	10.0	0.5	Sec
Transfer time	Transfer Time	0	250	2	Sec
Spring loading time	Spring Loading Time	1	250	3	Sec
Retry number	Retry Number	1	250	5	

Hardware Breaker Selection (Type of Breaker)

0- Breakers: Mains and Gen breakers have only close drives and if close drive off breaker will open. Parameters; GEN CLOSE BREAKER CONTACT TYPE, GEN CLOSE TIMER(if gen closed input selected), GEN OPEN TIMER(if gen closed input selected), MAIN CLOSE BREAKER CONTACT TYPE, MAINS CLOSE TIMER(if mains closed input selected), MAINS OPEN TIMER(if mains closed input selected), TRANSFER TIME.

Example: If Hardware Breaker Selection parameter is selected as 0;

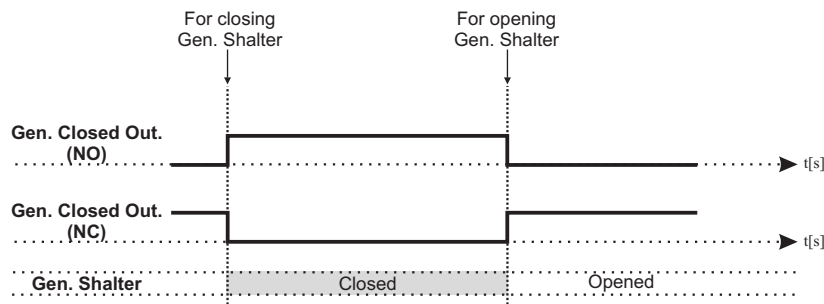

Note-1 : NO / NC : Normally Open / Normally Close
2 : NOR / PULS : Normal / Pulse

1- User Configured: Mains and Gen breakers have only close drives, when want to breaker close, close breaker output on and after 1 sec. open breaker output on and after breaker close pulse time open breaker output will off. When want to breaker open close breaker output and open breaker output will off.

Parameters; GEN CLOSE BREAKER CONTACT TYPE, GEN CLOSE TIMER(if gen closed input selected), GEN OPEN TIMER(if gen closed input selected), MAIN CLOSE BREAKER CONTACT TYPE, MAINS CLOSE TIMER(if mains closed input selected), MAINS OPEN TIMER(if mains closed input selected),BREAKER CLOSE PULSE TIME, TRANSFER TIME.

Example: If Hardware Breaker Selection parameter is selected as 1;

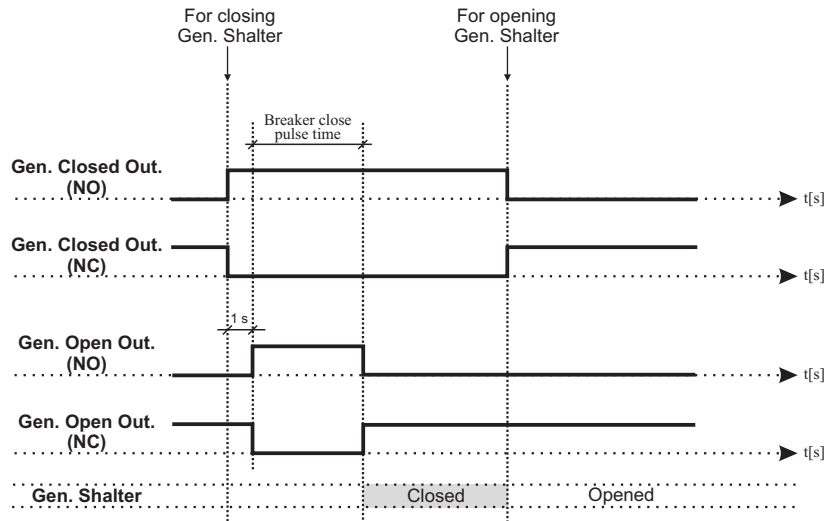

2- Motorised Breakers: User can select all the breaker types.

Parameters; GEN CLOSE BREAKER CONTACT TYPE, GEN CLOSE BREAKER RELAY TYPE, GEN CLOSE TIMER(if gen closed input selected), GEN OPEN BREAKER RELAY TYPE, GEN OPEN TIMER(if gen closed input selected), MAIN CLOSE BREAKER CONTACT TYPE, MAIN CLOSE BREAKER RELAY TYPE, MAINS CLOSE TIMER(if mains closed input selected), MAIN OPEN BREAKER RELAY TYPE, MAINS OPEN TIMER(if mains closed input selected), BREAKER CLOSE PULSE TIME(if Gen Close Breaker Relay Type or Main Close Breaker Relay Type parameter is selected as 1), BREAKER OPEN PULSE TIME(if Gen Open Breaker Relay Type or Main Open Breaker Relay Type parameter is selected as 1), TRANSFER TIME, SPRING LOADING TIME, RETRY NUMBER.

Example-1: GCB Close Diagram.

If Hardware Breaker Selection parameter is selected as 2 (motorised breakers), Gen. Close Breaker Relay Type parameter is selected as 1 (PULSE) and Gen. Open Breaker Relay Type parameter is selected as 1 (PULSE);

- GbCt:** Gen close timer
- brCP:** Breaker close pulse time
- brOP:** Breaker open pulse time
- sPLD:** Spring loading time
- rtNB:** Retry number

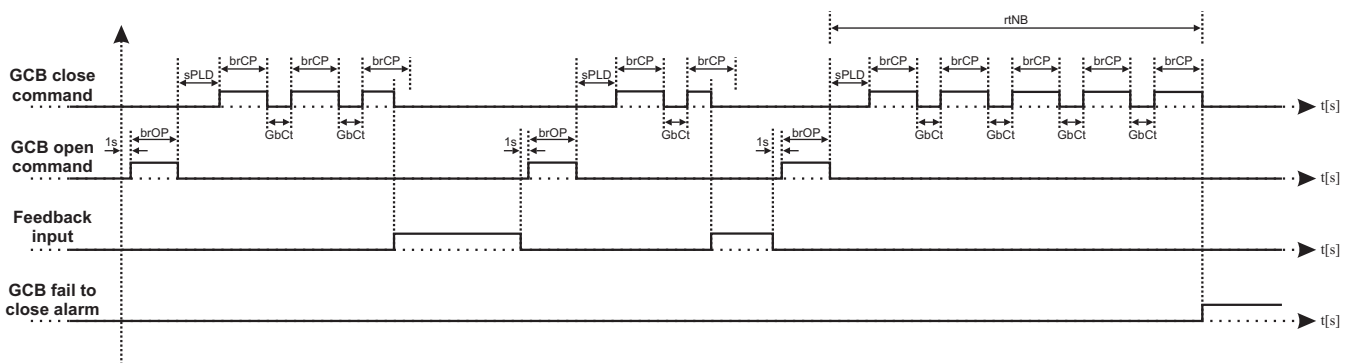

Example-2: GCB Open Diagram.

If Hardware Breaker Selection parameter is selected as 2 (motorised breakers), Gen. Close Breaker Relay Type parameter is selected as 1 (PULSE) and Gen. Open Breaker Relay Type parameter is selected as 1 (PULSE);

GbOt: Gen open timer

brOP: Breaker open pulse time

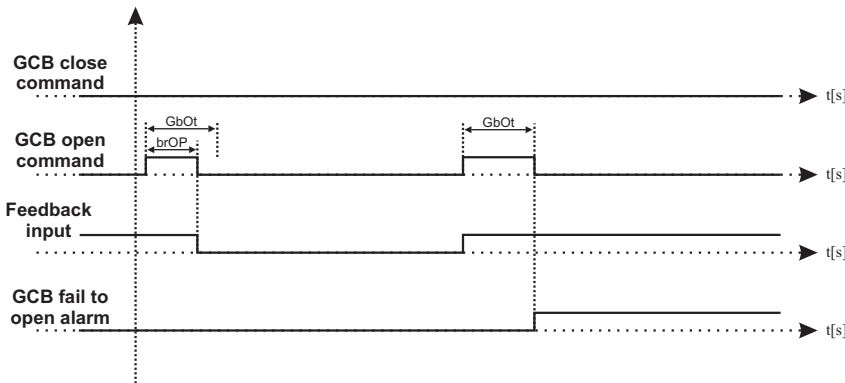

Gen Close Timer

This is used to monitor the closure of the generator contactor or breaker. It will only operate if an auxiliary input is configured as 'Generator Closed Auxiliary' and connected to the auxiliary on the generator contactor or breaker. Once a generator closed signal is issued the 'gen close timer' is initiated. Should the 'Generator Closed Auxiliary' input become active the timer the 'gen close timer' is cancelled. If the timer expires and the 'Generator Closed Auxiliary' has not become active the module will issue a 'generator failed to close' alarm.

Gen Open Timer

This is used to monitor the opening of the generator contactor or breaker. It will only operate if an auxiliary input is configured as 'Generator Closed Auxiliary' and connected to the auxiliary on the generator contactor or breaker. Once a generator open signal is issued the 'gen open timer' is initiated. Should the 'Generator Closed Auxiliary' input become in-active the timer 'gen open timer' is cancelled. If the timer expires and the 'Generator Closed Auxiliary' has not become in-active the module will issue a 'generator failed to open' alarm.

Mains Close Timer

This is used to monitor the closure of the mains contactor or breaker. It will only operate if an auxiliary input is configured as 'Mains Closed Auxiliary' and connected to the auxiliary on the mains contactor or breaker. Once a mains closed signal is issued the 'mains close timer' is initiated. Should the 'Mains Closed Auxiliary' input become active the timer the 'mains close timer' is cancelled. If the timer expires and the 'Mains Closed Auxiliary' has not become active the module will issue a 'mains failed to close' alarm.

Mains Open Timer

This is used to monitor the opening of the mains contactor or breaker. It will only operate if an auxiliary input is configured as 'Mains Closed Auxiliary' and connected to the auxiliary on the mains contactor or breaker. Once a mains open signal is issued the 'mains open timer' is initiated. Should the 'Mains Closed Auxiliary' input become in-active the timer the 'mains open timer' is cancelled. If the timer expires and the 'Mains closed auxiliary' has not become in-active the module will issue a 'mains failed to open' alarm.

Breaker Close Pulse Time

This is used to determine the duration of the Mains and Generator close signals. This timer is only used if Pulsed outputs are configured to be used.

Breaker Open Pulse Time

This is used to determine the duration of the Mains and Generator close signals. This timer is only used if Pulsed outputs are configured to be used.

Transfer Time

This is used to allow for fixed duration transfer breaks when switching from mains to generator and back. It can be used to ensure that the supply is removed from the load for fixed period of time to allow pumps/motors to come to rest etc.

Spring Loading Time

When the unit give open command to the (GCB or MCB) breaker and after that the unit want to give close command the same breaker, this time for between open and close commands, because if there is no delay between open and close commands can be problem the motorized switches.

Retry Number

The unit try to close (GCB or MCB) breaker number of this parameter. If each try there is no close feedback, after last try the alarm will be activated.

LCD DISPLAY (System->LCD display)		Min	Max	Default	Unit
Language	Language Selection	ENGLISH/CHINESE		ENGLISH	
Contrast	Contrast Setting	4	9	5	
Auto backlight off	Auto Backlight Off 0-DISABLE 1-ENABLE 2-ENABLE(only when engine is not running)	0	2	0	
Auto scroll time	Auto Scroll Time	0 (dis)	250	0	Sec
Auto scroll number	Auto Scroll Number	1	24	5	
Err. mesg scroll time	Scroll Time For Error Messages	1	250	2	Sec
Back to genset screen	Back To Genset Screen	0 (dis)	250	0 (dis)	Sec

Language Selection

Language selection: English or Chinese.

Digital Contrast

It is used to change contrast of LCD Display.

Auto Backlight Off

2- ENABLE: If any button is not pressed during 60 secs, LCD backlight is automatically changed power saving mode. If the engine is running, backlight is on continuously.

1- ENABLE: If any button is not pressed during 60 secs, LCD backlight is automatically changed power saving mode.

0- DISABLE: LCD backlight is on continuously.

Auto Scroll Time

The scroll time between all data display pages.

Auto Scroll Number

The number of data display pages that will be scrolled.

Scroll Time For Error Messages

Error messages are displayed the last line of LCD Display. If more than one error condition is present, each of them is displayed during time defined by Auto Scroll Timer parameter.

Back To Genset Screen

If any button is not pressed during the time defined in this parameter, LCD screen will automatically changed to the Genset page. **Note:** This parameter is only available at TRANS-AMF.TR device.

Note: dis = disable

COMMUNICATION (System->Communication)		Min	Max	Default	Unit
Slave address	Slave Address	1	247	1	
Baud rate	Baud Rate: 0 - 1200 baud 1 - 2400 baud 2 - 4800 baud 3 - 9600 baud 4 - 19200 baud 5 - 38400 baud	0	5	3	
Parity	Parity: 0-> None, 1-> Odd, 2-> Even	0	2	0	
Stop bit	Stop Bit (0-> 1 stop bit,1-> 2 stop bit)	0	1	0	
Datalog period	Datalog Period	0.0(dis)	999.9	1.0	Min
Timeout	Timeout	0(dis)	999	3	Min
ASCII/RTU selection	ModBus ASCII/RTU Selection	ASCII / RTU		ASCII	

Timeout

This parameter is used for the modem hardware reset. If the data communication is interrupted and this situation continues as this parameter, the modem hardware reset is performed.

ModBus ASCII/RTU Selection

This parameter is only functional for the USB, RS-232, RS-485 or RS-422 communication.

DATE & TIME SET (System->Date & time set)		Min	Max	Default	Unit
Year	Year	0	99		
Month	Month	1	12		
Day	Date	1	31		
Week	Day of week	1	7		
Hour	Hour	0	23		
Minute	Minute	0	59		
Second	Second	0	59		

Day of week 1=Monday,2=Tuesday,3=Wednesday,4=Thursday,5=Friday,6=Saturday,7=Sunday

DEFAULT SETTINGS (System->Default settings)		Min	Max	Default	Unit
Save setting to def.	Save setting to default	YES / NO		NO	
Reset default sets	Reset default sets	YES / NO		NO	
Reset factory sets	Reset factory sets	YES / NO		NO	

Save setting to default

If this parameter is selected as "Yes", the unit's currently parameters save as default sets. After this parameter is reset automatically to "No".

Reset default sets

If this parameter is selected as "Yes", the unit's parameters back to default sets. After this parameter is reset automatically to "No".

Reset factory sets

If this parameter is selected as "Yes", the unit's parameters back to factory sets. After this parameter is reset automatically to "No".

PASSWORD SETTINGS (System->Password settings)		Min	Max	Default	Unit
Operator password	Operator Password	0	9999	0	
Technician password	Technician Password	0	9999	0	

Operator Password

Use this option to change the Operator password. This password allows access to operator parameters section.

Technician Password

Use this option to change the Technician password. It allows access to both operator and technician parameters section.

Note: dis = disable

4.2.2 Mains

MAINS VOLT LEVEL (<i>Mains->Volt level</i>)		Min	Max	Default	Unit
Under volt trip	Mains Under Voltage	60	600	320	V \sim
Under volt reset	Mains Under Voltage Reset	60	600	340	V \sim
Over volt trip	Mains Over Voltage	60	600	440	V \sim
Over volt reset	Mains Over Voltage Reset	60	600	420	V \sim

MAINS FREQ. LEVEL (<i>Mains->Frequency level</i>)		Min	Max	Default	Unit
Under freq trip	Mains Under Frequency	20.0	75.0	45.0	Hz
Under freq reset	Mains Under Frequency Reset	20.0	75.0	48.0	Hz
Over freq trip	Mains Over Frequency	20.0	75.0	55.0	Hz
Over freq reset	Mains Over Frequency Reset	20.0	75.0	52.0	Hz

MAINS ACTIONS (<i>Mains->Actions</i>)		Min	Max	Default	Unit
Mains failure detect	Mains Failure Detection En/Dis: 0-DISABLE 1-ENABLE 2-ENABLE ON REMOTE	0	2	1	
Mains fail.stop mode	Look Mains Failure at Stop Mode En/Dis	ENABL/DISBL		ENABL	
Always return delay	Always Look Mains Return Delay	ENABL/DISBL		DISBL	

Mains Failure Detection En/Dis

0-DISABLE: The module will not monitor the mains supply.

1-ENABLE: The module will monitor the mains supply. If the mains supply go out side of limits, the module will initiate its automatic mains failure sequence. (If no inputs is selected as a remote start)

2-ENABLE ON REMOTE: The module will monitor the mains supply. If the mains supply go out side of limits, the module will initiate its automatic mains failure sequence. (Even if one of the inputs is selected as a remote start)

Look Mains Failure at Stop Mode En/Dis

ENABLE: As soon as the module detects a mains failure the mains contactor or breaker relay will be opened to remove the supply from the load. This is to prevent damage to the load in case of single-phase failure.

DISABLE: In the event of a mains failure the unit will attempt to maintain the supply to the load for the incoming AC mains supply until the generator is available to go on load. In the event of a generator failure the module will default back to the incoming AC mains supply.

Always Look Mains Return Delay

ENABLE: The module will always wait the Mains Return Delay parameter before transferring the load back to mains.

DISABLE: The module will wait the Mains Return Delay parameter while only the engine is running and the generator is available to go on load before transferring the load back to mains.

4.2.3 Generator

GENERATOR VOLT LEVEL (<i>Generator->Volt level</i>)		Min	Max	Default	Unit
Under volt shutdown	Generator Under Voltage Shutdown	60(dis)	600	320	V \sim
Under volt prealarm	Generator Under Voltage Pre-Alarm	60(dis)	600	340	V \sim
Under volt reset	Generator Under Voltage Pre-Alarm Reset	60	600	350	V \sim
Over volt shutdown	Generator Over Voltage Shutdown	60	600	440	V \sim
Over volt prealarm	Generator Over Voltage Pre-Alarm	60(dis)	600	420	V \sim
Over volt reset	Generator Over Voltage Pre-Alarm Reset	60	600	400	V \sim
Shutdown delay time	Generator Voltage Shutdown Delay Time	0.0	10.0	1.0	Sec

GENERATOR FREQ LEVEL (<i>Generator->Frequency level</i>)		Min	Max	Default	Unit
Nominal frequency	Nominal Alternator Frequency	30.0	75.0	50.0	Hz
Under freq shutdown	Generator Under Frequency Shutdown	30.0(dis)	75.0	43.0	Hz
Under freq prealarm	Generator Under Frequency Pre-Alarm	30.0(dis)	75.0	45.0	Hz
Under freq reset	Generator Under Frequency Pre-Alarm Reset	30.0	75.0	46.0	Hz
Over freq shutdown	Generator Over Frequency Shutdown	30.0(dis)	75.0	58.0	Hz
Over freq prealarm	Generator Over Frequency Pre-Alarm	30.0(dis)	75.0	55.0	Hz
Over freq reset	Generator Over Frequency Pre-Alarm Reset	30.0	75.0	54.0	Hz
Shutdown delay time	Generator Frequency Shutdown Delay Time	0.0	10.0	1.0	Sec

GEN CUR LEVEL & ACT (<i>Generator->Current level & act.</i>)		Min	Max	Default	Unit
Under cur. set	Generator Under Current Set	0	9999	1	A~
Under cur. prealarm	Generator Under Current Pre-Alarm	0(dis)	9999	dis	A~
Under cur. reset	Generator Under Current Pre-Alarm Reset	0	9999	5	A~
Under cur. act.	Generator Under Current Actions 0 - Disable 1 - Warning (Alarm Only, No Shutdown) 2 - Electrical Trip (Alarm/Off Load Generator Followed By Shutdown After Cooling) 3 - Shutdown (Alarm And Shutdown)	0(dis)	3	dis	
Under act. delay time	Generator Under Current Actions Delay Time	0	99	2	Sec
Over cur. IDMT alarm	Generator Over Current IDMT Alarm	ENABL/DISBL		DISBL	
Over cur. set	Generator Over Current Set	0	9999	9999	A~
Over cur. prealarm	Generator Over Current Pre-Alarm	0(dis)	9999	9990	A~
Over cur. reset	Generator Over Current Pre-Alarm Reset	0	9999	9980	A~
Over cur. act.	Generator Over Current Actions 0 - Disable 1 - Warning (Alarm Only, No Shutdown) 2 - Electrical Trip (Alarm/Off Load Generator Followed By Shutdown After Cooling) 3 - Shutdown (Alarm And Shutdown)	0(dis)	3	dis	
Over act. delay time	Generator Over Current Actions Delay Time	0	99	2	Sec
Short circuit cur.	Generator Short Circuit Current Set	0	9999	9999	A~
Earth fault cur.	Generator Earth Fault Current Set	0	9999	100	A~
Earth fault cur. act.	Generator Earth Fault Current Actions 0 - Disable 1 - Warning (Alarm Only, No Shutdown) 2 - Electrical Trip (Alarm/Off Load Generator Followed By Shutdown After Cooling) 3 - Shutdown (Alarm And Shutdown)	0(dis)	3	dis	
E.F. act. delay time	Generator Earth Fault Current Actions Delay Time	0	99	2	Sec
Unbalance load set	Unbalance Load Set	0	9999	0	A~
Unbalance load act.	Unbalance Load Actions 0 - Disable 1 - Warning (Alarm Only, No Shutdown) 2 - Electrical Trip (Alarm/Off Load Generator Followed By Shutdown After Cooling) 3 - Shutdown (Alarm And Shutdown)	0(dis)	3	dis	
Unbalance act. delay	Unbalance Load Actions Delay Time	0	99	2	Sec

Over cur. IDMT alarm

DISABLE: If the measurement value of current more than “Over cur. set” parameter and this condition is go on more than “Over act. delay time” parameter, the unit will give a “Over current” alarm.

ENABLE: If the measurement value of current more than “Over cur. set” parameter and this condition is go on more than “**Tripping time**”, the unit will give a “Over current” alarm.

$$\text{Tripping time} = \frac{(\text{“Over act. delay time” parameter}) \times (\text{“Over cur. set” parameter})}{(\text{Measured current}) - (\text{“Over cur. set” parameter})}$$

GEN POWER LEVEL (Generator->Power level)		Min	Max	Default	Unit
Under power set	Generator Under Power Set	0	9999	0	kVA
Under power prealarm	Generator Under Power Pre-Alarm	0(dis)	9999	dis	kVA
Under power reset	Generator Under Power Pre-Alarm Reset	0	9999	5	kVA
Under power act.	Generator Under Power Actions 0 - Disable 1 - Warning (Alarm Only, No Shutdown) 2 - Electrical Trip (Alarm/Off Load Generator Followed By Shutdown After Cooling) 3 - Shutdown (Alarm And Shutdown)	0(dis)	3	0(dis)	
Under act. delay time	Generator Under Power Action Delay Time	0	99	2	Sec
Over power IDMT alarm	Generator Over Power IDMT Alarm	ENABL/DISBL		DISBL	
Over power set	Generator Over Power Set	0	9999	0	kVA
Over power prealarm	Generator Over Power Pre-Alarm	0(dis)	9999	dis	kVA
Over power reset	Generator Over Power Pre-Alarm Reset	0	9999	0	kVA
Over power act.	Generator Over Power Actions 0 - Disable 1 - Warning (Alarm Only, No Shutdown) 2 - Electrical Trip (Alarm/Off Load Generator Followed By Shutdown After Cooling) 3 - Shutdown (Alarm And Shutdown)	0(dis)	3	0(dis)	
Over act. delay time	Generator Over Power Action Delay Time	0	99	2	Sec
Over load step 1	Generator Over Load Step 1	0	9999	9999	KVA
Over load step 1 rest	Generator Over Load Step 1 Reset	0	9999	9999	KVA
Over load step 1 act.	Generator Over Load Step 1 Actions 0 - Disable 1 - Status 2 - Warning Non-Latching 3 - Warning Latching	0(dis)	3	0(dis)	
Over load step 1 dly.	Generator Over Load Step 1 Action Delay Time	0	999.9	30.0	Sec
Over load step 2	Generator Over Load Step 2	0	9999	9999	KVA
Over load step 2 rest	Generator Over Load Step 2 Reset	0	9999	9999	KVA
Over load step 2 act.	Generator Over Load Step 2 Actions 0 - Disable 1 - Status 2 - Warning Non-Latching 3 - Warning Latching	0(dis)	3	0(dis)	
Over load step 2 dly.	Generator Over Load Step 2 Action Delay Time	0	999.9	30.0	Sec
Reverse power set	Reverse Power Set	-9999	0	0	kW
Reverse power act.	Reverse Power Actions 0 - Disable 1 - Warning (Alarm Only, No Shutdown) 2 - Electrical Trip (Alarm/Off Load Generator Followed By Shutdown After Cooling) 3 - Shutdown (Alarm And Shutdown)	0(dis)	3	0(dis)	
Rv.pow.act.delay time	Reverse Power Action Delay Time	0	99	2	Sec

Over power IDMT alarm

DISABLE: If the measurement value of power more than “Over power set” parameter and this condition is go on more than “Over act. delay time” parameter, the unit will give a “Over power” alarm.

ENABLE: If the measurement value of power more than “Over power set” parameter and this condition is go on more than “**Tripping time**”, the unit will give a “Over power” alarm.

$$\text{Tripping time} = \frac{(\text{“Over act. delay time” parameter}) \times (\text{“Over power set” parameter})}{(\text{Measured power}) - (\text{“Over power set” parameter})}$$

GEN WORKING CALENDAR (<i>Generator->Working calendar</i>)		Min	Max	Default	Unit
Disable/enable select	Working Calendar Disable or Enable	DISBL/ENABL	DISBL		
Start time on monday	Working Calendar Work Start Time on Monday	0.00	23.59	0.00	H.Min
Stop time on monday	Working Calendar Work Stop Time on Monday	0.00	23.59	23.59	H.Min
Start time on tues.	Working Calendar Work Start Time on Tuesday	0.00	23.59	0.00	H.Min
Stop time on tuesday	Working Calendar Work Stop Time on Tuesday	0.00	23.59	23.59	H.Min
Start time on wednes.	Working Calendar Work Start Time on Wednesday	0.00	23.59	0.00	H.Min
Stop time on wednes.	Working Calendar Work Stop Time on Wednesday	0.00	23.59	23.59	H.Min
Start time on thurs.	Working Calendar Work Start Time on Thursday	0.00	23.59	0.00	H.Min
Stop time on thursday	Working Calendar Work Stop Time on Thursday	0.00	23.59	23.59	H.Min
Start time on friday	Working Calendar Work Start Time on Friday	0.00	23.59	0.00	H.Min
Stop time on friday	Working Calendar Work Stop Time on Friday	0.00	23.59	23.59	H.Min
Start time on satur.	Working Calendar Work Start Time on Saturday	0.00	23.59	0.00	H.Min
Stop time on saturday	Working Calendar Work Stop Time on Saturday	0.00	23.59	23.59	H.Min
Start time on sunday	Working Calendar Work Start Time on Sunday	0.00	23.59	0.00	H.Min
Stop time on sunday	Working Calendar Work Stop Time on Sunday	0.00	23.59	23.59	H.Min

Calendar Disable or Enable

DISABLE: The unit will not monitor the working calendar parameters. If the mains supply go out side of limits, the unit will initiate automatic mains failure sequence.

ENABLE: The unit will monitor the working calendar parameters. If the mains supply go out side of limits, the unit will initiate automatic mains failure sequence only within the set "Start and Stop time parameters". Otherwise, the unit will not initiate automatic mains failure sequence and the "Auto" led will blink.

Note-1: If the "Start time parameter" of any day is set to "0.00" and the "Stop time parameter" is set to "23.59", the unit will initiate automatic mains failure sequence when the mains supply go out side of limits within that day.

Note-2: If the "Start and Stop time parameters" of any day are set the same, the unit will not initiate automatic mains failure sequence when the mains supply go out side of limits within that day.

GENERATOR GENERAL (<i>Generator->General</i>)		Min	Max	Default	Unit
Sens.option gen.freq	Sensing Options Generator Frq En/Dis	ENABL/DISBL		ENABL	
Sens.opt.pickup&flywh	Sensing Opt Pickup En/Dis & Flywheel	0(dis)	1000	DISBL	
All warning are latch	All Warnings Are Latched En/Dis	ENABL/DISBL		DISBL	
Stop mode on shutdown	Changed To Stop Mode On Shutdown Fail	ENABL/DISBL		DISBL	

Sensing Options Generator Frq En/Dis

ENABLE: Speed sensing will be derived from the generator output frequency.

DISABLE: Speed sensing not will be derived from the generator output frequency.

Sensing Options Pickup En/Dis & Flywheel

DISABLE: Speed sensing will not be derived from the magnetic pickup.

1-1000: Speed sensing will be derived from the magnetic pickup and the number is flywheel teeth on the engine.

All Warnings Are Latched En/Dis

ENABLE: Warnings and pre-alarms will latched when triggered. To reset the alarm either an external reset must be applied to one of the inputs or the 'Reset' pushbutton operated, once the triggering condition has cleared.

DISABLE: Normal operation, the warnings and pre-alarms (except spare inputs, because they have their latching or non-latching selections) will automatically reset once the triggering condition has cleared.

Changed To Stop Mode On Shutdown Fail

ENABLE: When the shutdown alarm received in automatic or test mode, the unit will change the operation mode to "STOP" mode.

DISABLE: When the shutdown alarm received in automatic or test mode, the unit will remain at the current operating mode.

4.2.4 Engine

ENGINE START OPTIONS (<i>Engine->Starting options</i>)		Min	Max	Default	Unit
Horn prior start	Audible Alarm Prior To Starting En/Dis	ENABL/DISBL		DISBL	
No. of crank attemp	Number Of Start Attempts	1	10	3	
Cranking time	Cranking Time	1	99	5	Sec
Crank rest time	Crank Rest Time	5	99	10	Sec
Pickup fail dely	Pickup Sensor Fail Delay	0.1	10.0	1.0	Sec

Audible Alarm Prior To Starting En/Dis

ENABLE: The audible alarm will sound before the engine starts. The sounder will become active once the start delay is initialised, it will remain active until either the engine reaches crank disconnect speed or pre-heat timers are cancelled.

Number Of Start Attempts

This value is the number of times the module will attempt to start the generator. Should the generator start the module will not attempt further starts. If the generator does not start after the final attempt, the module will give a 'Fail to start' alarm.

Cranking Time

This is the maximum amount of time that the module will energise the starter motor for during starting attempts once the starter has engaged.

Crank Rest Time

This is the amount of time the module will wait for between start attempts. This is to allow the starter motor to cool and the starter batteries to recover.

Note: dis = disable

ENG. CRANK DISCONNECT (<i>Engine->Crank disconnect</i>)		Min	Max	Default	Unit
Generator frequency	Crank Disconnect On Gen. Frequency	10.0	75.0	30.0	Hz
Engine speed	Crank Disconnect On Engine RPM	100	6000	500	RPM
Generator volt	Crank Disconnect On Gen. Voltage	60 (dis)	600	300	V \sim
Charge alt. volt	Crank Disconnect On Charge Alt. Voltage	6.0 (dis)	30.0	dis	V ---
Oil pres. enab./dis.	Crank Disconnect On Oil Pressure En/Dis	ENABL/DISBL		DISBL	
Oil pressure value	Oil Pressure Value	1.0	30.0	1.0	BAR
Check oil befor.start	Check Oil Pressure Before Start	ENABL/DISBL		ENABL	

The parameters in this page are used for engine started signals. If any of the selected signals appears, the unit assumes that the engine has started.

Crank Disconnect On Gen. Frequency

If the generator frequency over than 30.0 Hz, the unit assumes that the engine has started and the unit stop cranking.

Crank Disconnect On Engine RPM

If the generator speed over than 500 Rpm, the unit assumes that the engine has started and the unit stop cranking.

Crank Disconnect On Gen. Voltage

If the generator voltage over than 300 Vac, the unit assumes that the engine has started and the unit stop cranking.

Crank Disconnect On Charge Alt. Voltage

If the charge alternator voltage over than 6.1 Vdc, the unit assumes that the engine has started and the unit stop cranking. **Note:** If the charge generator input (terminal #35) is disconnect, this parameter selected as disabled (6.0 Vdc).

Crank Disconnect On Oil Pressure En/Dis

This parameter is used for to activate of the crank disconnect on oil pressure feature.

Oil Pressure Value

If the oil pressure sender over than this value, the unit assumes that the engine has started and the unit stop cranking.

Check Oil Pressure Before Start

If this parameter is enabled, the unit will not be allowed to crank if the oil pressure isn't seen as being low.

ENGINE SPEED SETS (<i>Engine->Speed settings</i>)		Min	Max	Default	Unit
Nominal speed	Nominal Speed	500	5000	1500	RPM
Under speed shutdown	Engine Under Speed Shutdown	500(dis)	5000	dis	RPM
Under speed prealarm	Engine Under Speed Prealarm	500(dis)	5000	dis	RPM
Under speed reset	Engine Under Speed Prealarm Reset	500	5000	500	RPM
Over speed shutdown	Engine Over Speed Shutdown	500(dis)	5000	dis	RPM
Over speed prealarm	Engine Over Speed Prealarm	500(dis)	5000	dis	RPM
Over speed reset	Engine Over Speed Prealarm Reset	500	5000	500	RPM
Shutdown delay time	Engine Speed Shutdown Delay Time	0.0	10.0	1.0	Sec

The parameters in this page are used for the generator speed low and high alarms.

Note: dis = disable

ENGINE PLANT BATTERY (<i>Engine->Plant battery</i>)		Min	Max	Default	Unit
Under volt shutdown	Battery Undervolts Shutdown	6.0(dis)	30.0	dis	V ₋₋₋
Under volt warning	Battery Undervolts Warning	6.0(dis)	30.0	11.0	V ₋₋₋
Under volt reset	Battery Undervolts Warning Reset	6.0	30.0	11.5	V ₋₋₋
Under volt delay	Battery Undervolts Volts Delay	0.0	120.0	1.0	Sec
Over volt shutdown	Battery Overvolts Shutdown	6.0(dis)	30.0	dis	V ₋₋₋
Over volt warning	Battery Overvolts Warning	6.0(dis)	30.0	29.0	V ₋₋₋
Over volt reset	Battery Overvolts Warning Reset	6.0	30.0	28.5	V ₋₋₋
Over volt delay	Battery Overvolts Delay	0.0	120.0	1.0	Sec
Alt. chg. warning	Charge Alternator Warning	6.0(dis)	30.0	dis	V ₋₋₋

The parameters in this page are used for the battery voltage low and high alarms and the charge alternator voltage warning.

CANBUS ECU (<i>Engine->CanBus ECU</i>)		Min	Max	Default	Unit
Baud rate	Baud Rate: 0 - 20 1 - 50 2 - 100 3 - 125 4 - 250 5 - 500 6 - 800 7 - 1.000	0	7	4	kBaud
J1939 ECU type	J1939 ECU Type Selection: 0 - Disable 1 - Standard 2 - Volvo EMS1 3 - Volvo EMS2 4 - Volvo EMS2b 5 - Volvo EDC3 6 - Volvo EDC4 7 - Deutz EMR2 8 - Deutz EMR3 9 - Perkins 1300 10 - Perkins ADEM3 11 - Perkins ADEM4 12 - Scania S6 13 - MAN MFR 14 - Cummins ISB 15 - Cummins CM570 16 - Cummins CM850 17 - Cummins CM2150E 18 - Cummins CM2250 19 - Detroit DDEC 20 - John Deere 21 - MTU ADEC 22 - MTU ECU8 23 - MTU ECU8 SAM 24 - Yuchai 25 - Kubota	0(dis)	25	0	
Device address	Device Address	0	255	17	
SPN version	SPN version	1	3	1	
ECU remote control	ECU Remote Control via J1939	ENABL/DISBL		ENABL	
Speed control enable	Speed Control via J1939	ENABL/DISBL		ENABL	
Oil pres cont. enab	Oil Pressure Control via J1939	ENABL/DISBL		DISBL	
Temp. control enable	Coolant Temperature Control via J1939	ENABL/DISBL		DISBL	
Speed set point	Speed Set Point Selection	1500 / 1800		1500	RPM
Speed correction	Speed Correction Value	0	100	50	%

Baud Rate

It defines the used Baud rate.

Note: All participants on the CAN bus must use the same Baud rate.

J1939 ECU Type Selection

The J1939 interface of this unit can be operated with different ECUs. This parameter determines the operating mode of the used ECUs. If this parameter is selected as “disable”, No messages will be sent or received.

Note: Volvo EMS2 engine types: TAD734, TAD940, TAD941, TAD1640, TAD1641, TAD1642.
 Volvo EDC3 engine types: TAD1240, TAD1241, TAD1242.
 Volvo EDC4 engine types: TD520, TAD520, TD720, TAD720, TAD721, TAD722.
 Perkins ADEM3 / ADEM4 engine types: 2306, 2506, 1106, 2806.
 Scania S6 engine types: DC 9, DC 12, DC 16.
 MAN MFR ECU type: EDC7.
 Cummins ISB engine type: QSM11.
 Cummins CM570 engine type: QSX15.
 Cummins CM850, Cummins CM2150E, Cummins CM2250 engine types: QSB5, QSB7, QSL9, QSK50, QSK60, QSK19, QSK38.
 MTU ADEC engine types: Series 2000, 4000.
 MTU UCU8 engine types: Series 1600.

ECU Device Address

The unit sends J1939 request and control messages with this ID. It must be changed for different ECU types according to the following table. The ECU listens only to control messages, if they are sent to the correct address.

<i>Volvo EMS1, Volvo EMS2, Volvo EMS2b, Volvo EDC3</i>	<i>Volvo EDC4, Deutz EMR2, Deutz EMR3</i>	<i>Perkins 1300, Perkins ADEM3, Perkins ADEM4</i>	<i>Scania S6</i>	<i>MAN MFR</i>
17	3	43	39	253

<i>Cummins ISB, Cummins CM570, Cummins CM850, Cummins CM2150E, Cummins CM2250</i>	<i>Detroit DDEC</i>	<i>John Deere</i>	<i>MTU ADEC, MTU ECU8 SAM</i>	<i>MTU ECU8</i>	<i>Yuchai</i>	<i>Kubota</i>
220	231	3	1	234	3	228

SPN Version

There are 4 different Suspect Parameter Number versions with J1939 protocol. The device has ability to detecting version 4 automatically. Therefore, this parameter is important to show alarm messages correctly except version 4.

Note: Changing above mentioned parameter becomes only effective after restarting the unit.

ECU Remote Control Via J1939

If this parameter is selected as “Enable”, The unit sends remote control messages to the ECU if the selected ECU type is supporting the J1939 Remote control Messages. Available messages are engine start-stop, 50/60 Hz selection or Idle mode. For some ECUs;

Parameter	Volvo EMS1, Volvo EMS2, Volvo EMS2b, Volvo EDC3	Volvo EDC4, Deutz EMR2, Deutz EMR3	Perkins 1300, Perkins ADEM3, Perkins ADEM4	Scania S6	MAN MFR	Standard
Remote Start	Yes	No	No	Yes	Yes	No
Remote Stop	Yes	No	No	Yes	Yes	No
50/60 Hz Selection	Yes	No	No	Yes	No	No
Idle Mode	Yes	No	No	Yes	Yes	No

Parameter	Cummins ISB, Cummins CM570, Cummins CM850, Cummins CM2250	Cummins CM2150E	Detroit DDEC	John Deere	MTU ADEC, MTU ECU8, MTU ECU8 SAM	Yuchai	Kubota
Remote Start	Yes	No	No	No	Yes	No	No
Remote Stop	Yes	No	No	No	Yes	No	Yes
50/60 Hz Selection	Yes	Yes	No	No	Yes	No	No
Idle Mode	Yes	Yes	No	No	No	No	No

If this parameter is selected as “Disable”, The ECU remote control via the J1939 protocol will be disabled.

Speed Control via J1939

If this parameter is selected as “Enable”, The speed sensing from J1939 ECU will be used for the speed (Rpm) failures.

Oil Pressure Control via J1939

If this parameter is selected as “Enable”, The oil pressure sensing from J1939 ECU will be used for the oil pressure failures and the engine started signal.

Coolant Temperature Control via J1939

If this parameter is selected as “Enable”, The coolant temperature sensing from J1939 ECU will be used for the coolant temperature failures.

Speed Set Point Selection (50/60 Hz)

This parameter used for to select the requested engine speed as 1500Rpm (50Hz) or 1800Rpm (60Hz). **Note:** The scenario; first change the parameter, next wait at least 5 seconds, and then start the engine.

Speed Correction Value

This parameter can be changed between 0 and 100%. The engine should change the speed as follows:

0% = rated speed – speed deviation ECU e.g. 1500 – 120 = 1380rpm

50% = rated speed e.g. = 1500rpm

100% = rated speed + speed deviation ECU e.g. 1500 + 120 = 1620rpm

CANBUS ERROR SET (Engine->CanBus error set)		Min	Max	Default	Unit
CAN fault actions	Can Fault Actions: 0- Disable 1- Warning Non-Latching 2- Warning (Alarm Only, No Shutdown) 3- Electrical Trip (Alarm/Off Load Generator Followed By Shutdown After Cooling) 4- Shutdown (Alarm And Shutdown)	0(dis)	4	0	
CAN fault activation	Can Fault Activation: 0- Active From Starting 1- Active From Safety On 2- Always Active	0	2	0	
CAN fault delay	Can Fault Delay	2	250	10	Sec
Amber warn.actions	J1939 Amber Warning Lamp Actions: 0- Disable 1- Warning Non-Latching 2- Warning (Alarm Only, No Shutdown) 3- Electrical Trip (Alarm/Off Load Generator Followed By Shutdown After Cooling) 4- Shutdown (Alarm And Shutdown)	0(dis)	4	0	
Amber warn.activation	J1939 Amber Warning Lamp Activation: 0- Active From Starting 1- Active From Safety On 2- Always Active	0	2	2	
Amber warn.delay	J1939 Amber Warning Lamp Delay	0	250	2	Sec
Red stop actions	J1939 Red Stop Lamp Actions: 0- Disable 1- Warning Non-Latching 2- Warning (Alarm Only, No Shutdown) 3- Electrical Trip (Alarm/Off Load Generator Followed By Shutdown After Cooling) 4- Shutdown (Alarm And Shutdown)	0(dis)	4	0	
Red stop activation	J1939 Red Stop Lamp Activation: 0- Active From Starting 1- Active From Safety On 2- Always Active	0	2	2	
Red stop delay	J1939 Red Stop Lamp Delay	0	250	2	Sec

Note: dis = disable

ENGINE MAINTENANCE (<i>Engine->Maintenance</i>)		Min	Max	Default	Unit
Running hour interval	Running Hours Interval	0(dis)	9999	5000	Hour
Maint. date interval	Maintenance Date Interval	0(dis)	12	6	Month
Eng. stop when maint	Force Engine Shutdown When Maintenance Is Due	ENABL/DISBL		DISBL	
Engine running hour	Engine Running Hour	0	30000	0	
Maintenance okay	Maintenance Okay	YES/NO		NO	

Engine Running Hour: The user can change the engine running hours value by using this parameter.

LOAD TEST (<i>Engine->Load test</i>)		Min	Max	Default	Unit
Disable/enable select	Disable, No Load or On Load Selection	0-DISABLE 1-NO LOAD 2-ON LOAD		1-NO LOAD	

Disable, No Load or On Load Selection

DISABLE: Test mode disable.

NO LOAD: The generator will be running without taking the load in test mode.

ON LOAD: The generator will be running with load in test mode.

Note: dis = disable

EXERCISE (Engine->Exercise)		Min	Max	Default	Unit
Disable/enable select	Exercise Disable or Enable	DISBL/ENABL		DISBL	
Start time1 on monday	Exercise Start Time 1 on Monday	0.00	23.59	0.00	H.Min
Stop time1 on monday	Exercise Stop Time 1 on Monday	0.00	23.59	0.00	H.Min
Start time2 on monday	Exercise Start Time 2 on Monday	0.00	23.59	0.00	H.Min
Stop time2 on monday	Exercise Stop Time 2 on Monday	0.00	23.59	0.00	H.Min
Start time3 on monday	Exercise Start Time 3 on Monday	0.00	23.59	0.00	H.Min
Stop time3 on monday	Exercise Stop Time 3 on Monday	0.00	23.59	0.00	H.Min
Start time4 on monday	Exercise Start Time 4 on Monday	0.00	23.59	0.00	H.Min
Stop time4 on monday	Exercise Stop Time 4 on Monday	0.00	23.59	0.00	H.Min
Start time1 on tues.	Exercise Start Time 1 on Tuesday	0.00	23.59	0.00	H.Min
Stop time1 on tuesday	Exercise Stop Time 1 on Tuesday	0.00	23.59	0.00	H.Min
Start time2 on tues.	Exercise Start Time 2 on Tuesday	0.00	23.59	0.00	H.Min
Stop time2 on tuesday	Exercise Stop Time 2 on Tuesday	0.00	23.59	0.00	H.Min
Start time3 on tues.	Exercise Start Time 3 on Tuesday	0.00	23.59	0.00	H.Min
Stop time3 on tuesday	Exercise Stop Time 3 on Tuesday	0.00	23.59	0.00	H.Min
Start time4 on tues.	Exercise Start Time 4 on Tuesday	0.00	23.59	0.00	H.Min
Stop time4 on tuesday	Exercise Stop Time 4 on Tuesday	0.00	23.59	0.00	H.Min
Start time1 on wednes	Exercise Start Time 1 on Wednesday	0.00	23.59	0.00	H.Min
Stop time1 on wednes.	Exercise Stop Time 1 on Wednesday	0.00	23.59	0.00	H.Min
Start time2 on wednes	Exercise Start Time 2 on Wednesday	0.00	23.59	0.00	H.Min
Stop time2 on wednes.	Exercise Stop Time 2 on Wednesday	0.00	23.59	0.00	H.Min
Start time3 on wednes	Exercise Start Time 3 on Wednesday	0.00	23.59	0.00	H.Min
Stop time3 on wednes.	Exercise Stop Time 3 on Wednesday	0.00	23.59	0.00	H.Min
Start time4 on wednes	Exercise Start Time 4 on Wednesday	0.00	23.59	0.00	H.Min
Stop time4 on wednes.	Exercise Stop Time 4 on Wednesday	0.00	23.59	0.00	H.Min
Start time1 on thurs.	Exercise Start Time 1 on Thursday	0.00	23.59	0.00	H.Min
Stop time1 on thurs.	Exercise Stop Time 1 on Thursday	0.00	23.59	0.00	H.Min
Start time2 on thurs.	Exercise Start Time 2 on Thursday	0.00	23.59	0.00	H.Min
Stop time2 on thurs.	Exercise Stop Time 2 on Thursday	0.00	23.59	0.00	H.Min
Start time3 on thurs.	Exercise Start Time 3 on Thursday	0.00	23.59	0.00	H.Min
Stop time3 on thurs.	Exercise Stop Time 3 on Thursday	0.00	23.59	0.00	H.Min
Start time4 on thurs.	Exercise Start Time 4 on Thursday	0.00	23.59	0.00	H.Min
Stop time4 on thurs.	Exercise Stop Time 4 on Thursday	0.00	23.59	0.00	H.Min
Start time1 on friday	Exercise Start Time 1 on Friday	0.00	23.59	0.00	H.Min
Stop time1 on friday	Exercise Stop Time 1 on Friday	0.00	23.59	0.00	H.Min
Start time2 on friday	Exercise Start Time 2 on Friday	0.00	23.59	0.00	H.Min
Stop time2 on friday	Exercise Stop Time 2 on Friday	0.00	23.59	0.00	H.Min
Start time3 on friday	Exercise Start Time 3 on Friday	0.00	23.59	0.00	H.Min
Stop time3 on friday	Exercise Stop Time 3 on Friday	0.00	23.59	0.00	H.Min
Start time4 on friday	Exercise Start Time 4 on Friday	0.00	23.59	0.00	H.Min
Stop time4 on friday	Exercise Stop Time 4 on Friday	0.00	23.59	0.00	H.Min
Start time1 on satur.	Exercise Start Time 1 on Saturday	0.00	23.59	0.00	H.Min
Stop time1 on satur.	Exercise Stop Time 1 on Saturday	0.00	23.59	0.00	H.Min
Start time2 on satur.	Exercise Start Time 2 on Saturday	0.00	23.59	0.00	H.Min
Stop time2 on satur.	Exercise Stop Time 2 on Saturday	0.00	23.59	0.00	H.Min
Start time3 on satur.	Exercise Start Time 3 on Saturday	0.00	23.59	0.00	H.Min
Stop time3 on satur.	Exercise Stop Time 3 on Saturday	0.00	23.59	0.00	H.Min
Start time4 on satur.	Exercise Start Time 4 on Saturday	0.00	23.59	0.00	H.Min
Stop time4 on satur.	Exercise Stop Time 4 on Saturday	0.00	23.59	0.00	H.Min

Note: dis = disable

Start time1 on sunday	Exercise Start Time 1 on Sunday	0.00	23.59	0.00	H.Min
Stop time1 on sunday	Exercise Stop Time 1 on Sunday	0.00	23.59	0.00	H.Min
Start time2 on sunday	Exercise Start Time 2 on Sunday	0.00	23.59	0.00	H.Min
Stop time2 on sunday	Exercise Stop Time 2 on Sunday	0.00	23.59	0.00	H.Min
Start time3 on sunday	Exercise Start Time 3 on Sunday	0.00	23.59	0.00	H.Min
Stop time3 on sunday	Exercise Stop Time 3 on Sunday	0.00	23.59	0.00	H.Min
Start time4 on sunday	Exercise Start Time 4 on Sunday	0.00	23.59	0.00	H.Min
Stop time4 on sunday	Exercise Stop Time 4 on Sunday	0.00	23.59	0.00	H.Min

Exercise Disable or Enable

DISABLE: The exercise function is disabled. The unit will not monitor the exercise parameters.

ENABLE: The unit will monitor the exercise parameters.

When the start time of any day is reached, the unit will start the generator.

When the stop time of the same day is reached, the unit will stop the generator.

Note-1: If the “Start and Stop time parameters” of any day are set the same, the exercise function for that day will be passive.

Note-2: If the “Start time parameter” of any day is set larger than the “Stop time parameter”, the exercise function for that day will be passive.

ENGINE GENERAL (<i>Engine->General</i>)		Min	Max	Default	Unit
Fuel selection	Engine Fuel Selection	0-GAS 1-DIESEL 2-GASOLINE		1-DIESEL	
Stop solenoid time	Stop Solenoid Time	1	99	20	Sec
Ignition delay	Ignition Delay	1	99	5	Sec
Gas valve delay	Gas Valve Delay	1	99	5	Sec
Min. of ignition speed	Minimum Ignition Speed	10	1500	200	RPM
Choke time	Choke Time	0.0	30.0	0.8	Sec

Engine Fuel (Gas/ Diesel/Gasoline) Selection

Gas, Diesel or Gasoline engines can be selected.

Stop Solenoid Time

This timer is used if the unit is configured to operate an Energise to stop engine. It dictates the duration that the Stop Solenoid output will remain active after the module has detected the engine has come to rest. If the Stop Solenoid output is not configured, this timer will still operate, preventing an immediate restart.

Ignition Delay

With gas engines often a purging operation is desired before starting. With the engaging of the starter the ignition delay is started. If the 'min ignition speed' is reached after expiry of this time, the configurable relay output 'ignition' is set.

Gas Valve Delay

By setting the ignition relay the gas valve delay is started. After the expiry of the set time as long as the number of revolutions is higher than the minimum ignition speed, the gas valve is set. When the necessary engine shutdown process, gas valve is de-energised.

Minimum Ignition Speed

After expiry of the ignition delay the number of revolutions set must be reached, so that the configurable relay output 'ignition' will be set.

Choke Time

This timer dictates that how long choke output will be active in gasoline engines.

[s]
[s]
[s]
[s]

t_r
 t_{ID}
 t_{GV}
 t_D

Interval between 2 start attempts
Ignition delay
Gas valve delay
Engine delayed monitoring

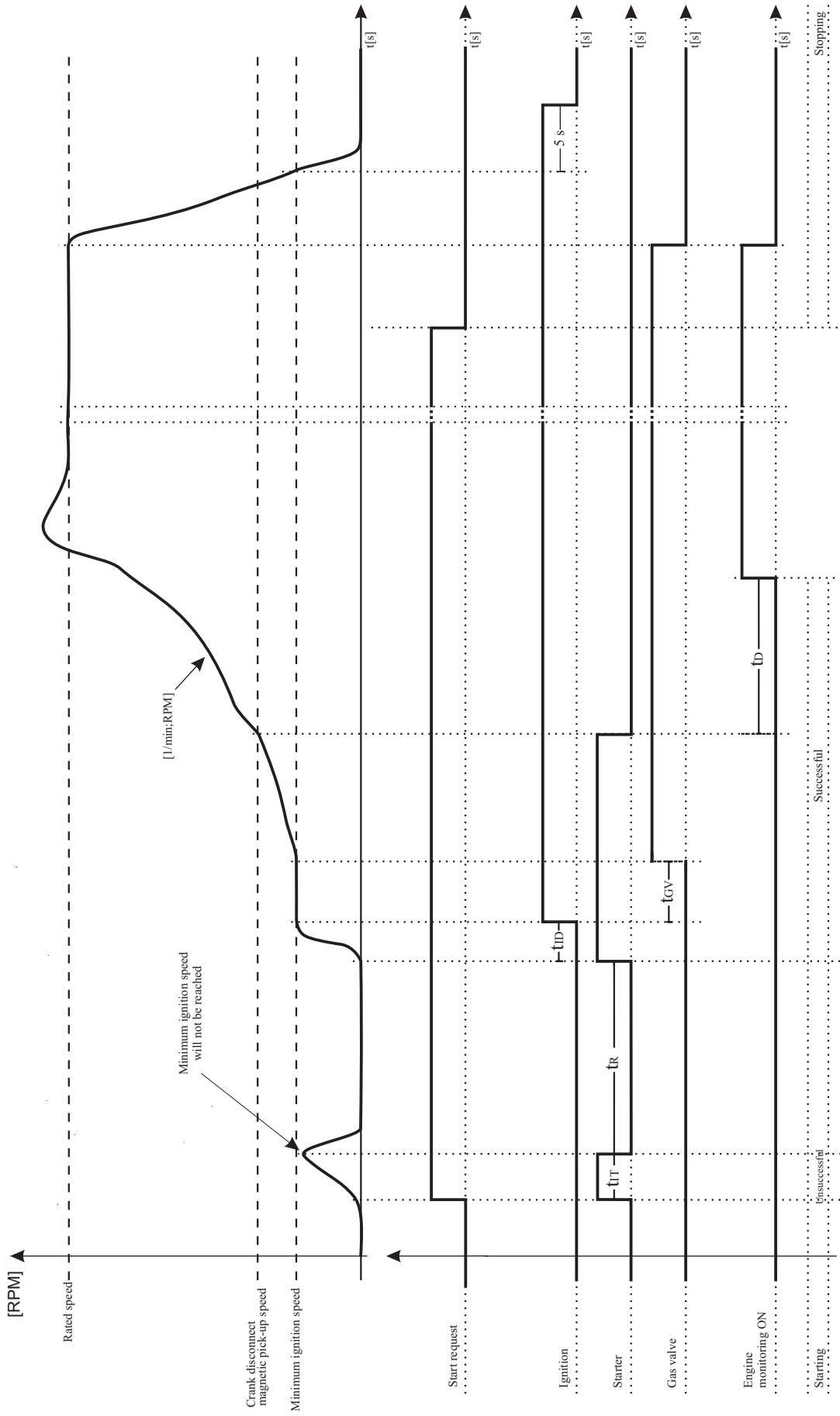

Start/Stop Diagram for GAS ENGINE

t_{PH} Preheating time [s]
 t_{CR} Engagement time [s]
 t_R Interval between 2 start attempts [s]
 t_D Engine delayed monitoring [s]

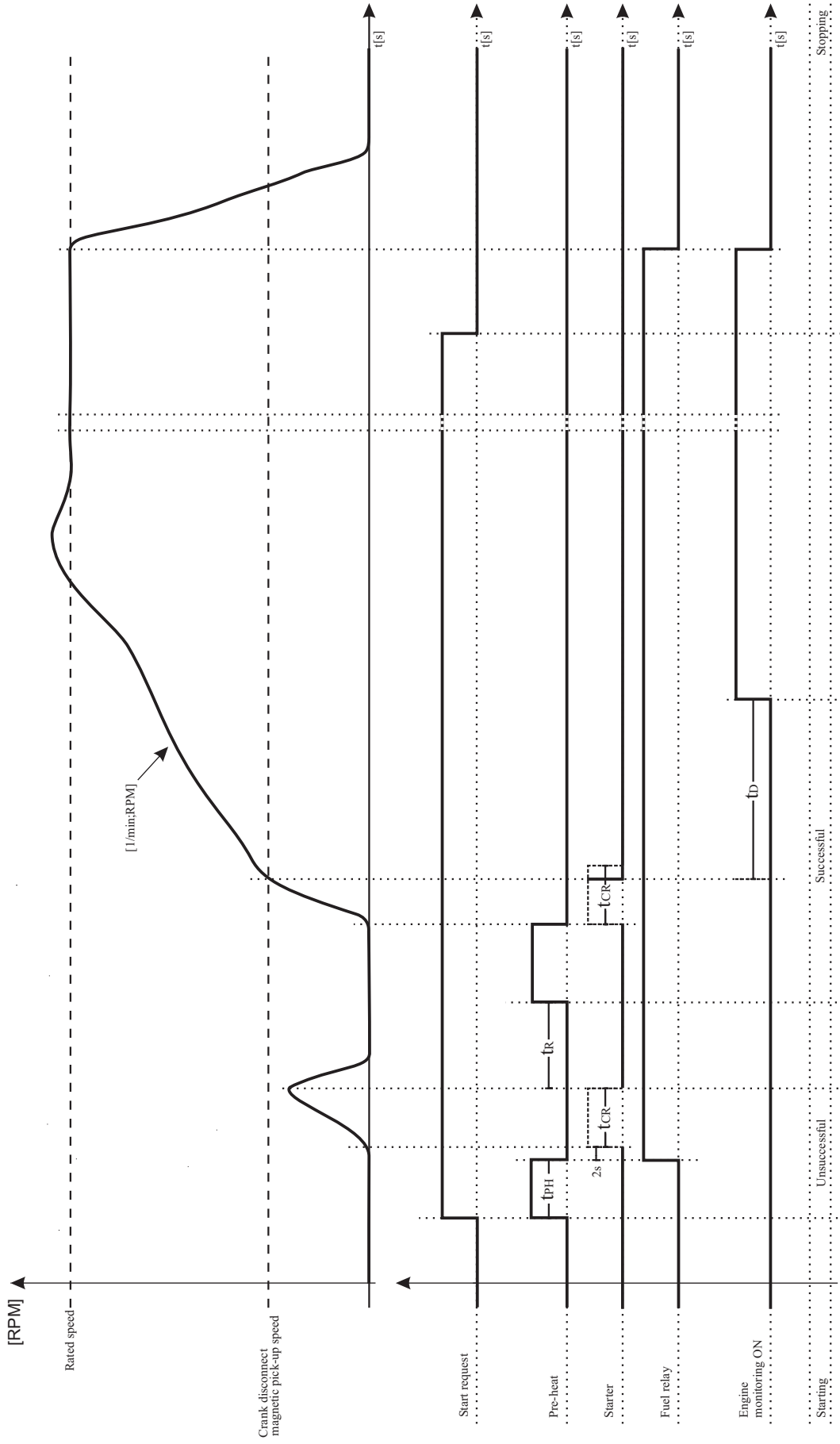

Start/Stop Diagram for DIESEL ENGINE

[s]
[s]
[s]
[s]
[s]

Preheating time
Engagement time
Interval between 2 start attempts
Engine delayed monitoring
Choke time

t_{PH}
 t_{CR}
 t_R
 t_D
 t_{CH}

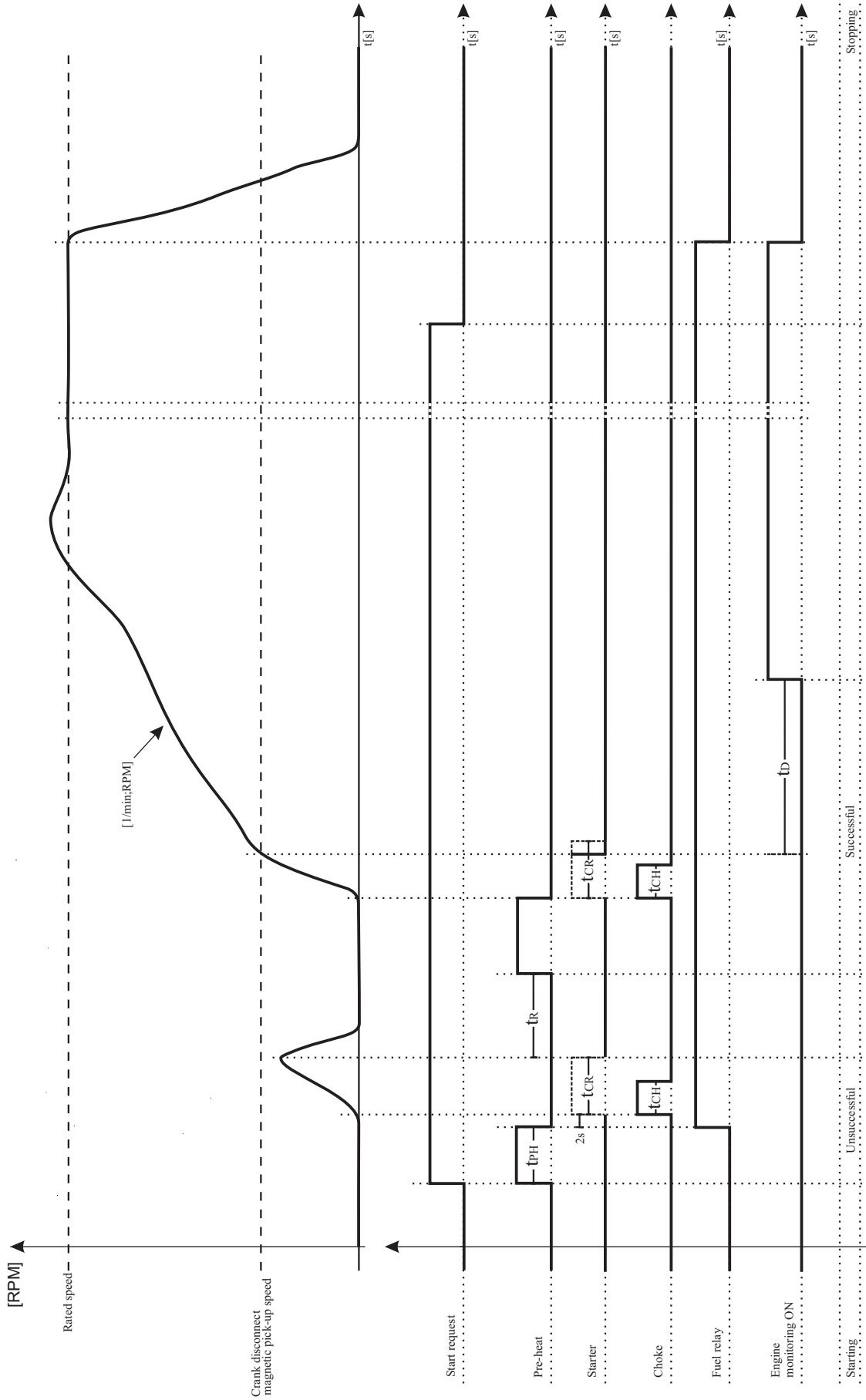

Start/Stop Diagram for GASOLINE ENGINE

4.2.5 Inputs

SENDER INPUTS (<i>Inputs->Sender inputs</i>)		Min	Max	Default	Unit
Oil pressure unit	Oil Pressure Unit	BAR/PSI/KPA		BAR	
Oil press. input type	Oil Pressure Input Type	0 - Not Used (Disable) 1 - Digital NC 2 - Digital NO 3 - VDO 5 BAR 4 - VDO 7 BAR 5 - VDO 10 BAR 6 - DATCON 5 BAR 7 - DATCON 7 BAR 8 - MURPHY 7 BAR 9 - User Configured		0 (dis)	
Oil pressure prealarm	Oil Pressure Pre-Alarm	0.0 (dis)	30.0	1.2	BAR
Oil pressure reset	Oil Pressure Pre-Alarm Reset	0.0	30.0	1.4	BAR
Oil pressure shutdown	Oil Pressure Shutdown	0.0	30.0	1.0	BAR
Temperature unit	Coolant Temperature Unit	°C/°F		°C	
Temp. input type	Coolant Temperature Input Type	0 - Not Used (Disable) 1 - Digital NC 2 - Digital NO 3 - VDO 120 °C 4 - VDO 150 °C 5 - DATCON 6 - MURPHY 7 - PT100 8 - User Configured		0 (dis)	
Temp. sensor break	Temperature Sensor Break	0 - Disable 1 - Enable From Safety On (3min. delayed) 2 - Always Enable		0 (dis)	
High temp. prealarm	High Temperature Pre-Alarm	0 (dis)	300	90	°C
High temp. reset	High Temp. Pre-Alarm Reset	0	300	88	°C
High temp. shutdown	High Temperature Shutdown	0	300	95	°C
Low temp. warning	Low Temperature Warning	0 (dis)	70	0 (dis)	°C
Heater control ON	Coolant Heater Control On	0 (dis)	300	0 (dis)	°C
Heater control OFF	Coolant Heater Control Off	0	300	45	°C
Water pump on time	Water Pump On Time	0	9999	5	Sec
Water pump off time	Water Pump Off Time	0	9999	5	Sec
Conf. AI1 unit	Configurable Analog Input-1 Unit	BAR/PSI/KPA/°C/°F/%/Lt		%	
Conf. AI1 type	Configurable Analog Input-1 Type	0- Not Used (Disable) 1- Digital NC 2- Digital NO 3- VDO OHM (10-180) 4- VDO TUBE (90-0) 5- US OHM (240-33) 6- ELS11 OHM (0-190) 7- FORD (73-10) 8- ELS13 OHM (0-190) 9- ELS30 OHM (0-190) 10- DAVITEQ (RS485)*1 11- KUS CLS2 (RS485)*1 12- MSL 790 (RS485)*1 13- CSFL 790 (RS485)*1 14- User Configured		0 (dis)	

Note*1: These sensor types can only be used in the Trans-AMF.RS485 units.

The USB communication interface can not be used when one of these sensor types is selected.

Conf. AI1 indication	If Conf. AI1 type is "Digital" 0- Status 1- Warning Non-Latching 2- Warning Latching 3- Electrical Trip 4- Shutdown	0	4	0	
Conf. AI1 activation	If Conf. AI1 type is "Digital" 0- Active From Starting 1- Active From Safety On 2- Always Active	0	2	2	
Conf. AI1 active dely	Configurable Analog Input-1 Active Delay (If Conf. AI1 type is "Digital")	0	250	0	Sec
Conf. AI1 low prearm	Config. Analog Input-1 Low Pre-Alarm	0 (dis)	3000	0 (dis)	%
Conf. AI1 low reset	Config. Analog Input-1 Low Reset	0	3000	60	%
Conf. AI1 low shutdwn	Config. Analog Input-1 Low Shutdown	0 (dis)	3000	0 (dis)	%
Conf. AI1 high prealr	Config. Analog Input-1 High Pre-Alarm	0 (dis)	3000	0 (dis)	%
Conf. AI1 high reset	Config. Analog Input-1 High Reset	0	3000	90	%
Conf. AI1 high shutd.	Config. Analog Input-1 High Shutdown	0 (dis)	3000	0 (dis)	%
Conf. AI1 control ON	Config. Analog Input-1 control ON	0 (dis)	3000	0 (dis)	%
Conf. AI1 control OFF	Config. Analog Input-1 control OFF	0	3000	75	%
Fuel filling max.time	Fuel Filling Maximum Time	0 (dis)	30000	0 (dis)	Sec
Fuel fill.alarm reset	Fuel Filling Alarm Reset	YES/NO		NO	
Fuel consumpt. reset	Fuel Consumption Reset	YES/NO		NO	
Fuel tank capacity	Fuel Tank Capacity	0	30000	100	Lt
Conf. AI2 unit	Configurable Analog Input-2 Unit	BAR/PSI/KPA/°C/°F/%/Lt		°C	
Conf. AI2 type	Configurable Analog Input-2 Type	0 - Not Used (Disable) 1 - Digital NC 2 - Digital NO 3 - VDO 120 °C 4 - VDO 150 °C 5 - DATCON 6 - MURPHY 7 - PT100 8 - User Configured		0 (dis)	
Conf. AI2 indication	If Conf. AI2 type is "Digital" 0- Status 1- Warning Non-Latching 2- Warning Latching 3- Electrical Trip 4- Shutdown	0	4	0	
Conf. AI2 activation	If Conf. AI2 type is "Digital" 0- Active From Starting 1- Active From Safety On 2- Always Active	0	2	2	
Conf. AI2 active dely	Configurable Analog Input-2 Active Delay (If Conf. AI2 type is "Digital")	0	250	0	Sec
Conf. AI2 low prearm	Config. Analog Input-2 Low Pre-Alarm	0 (dis)	300	0 (dis)	°C
Conf. AI2 low reset	Config. Analog Input-2 Low Reset	0	300	60	°C
Conf. AI2 low shutdwn	Config. Analog Input-2 Low Shutdown	0 (dis)	300	0 (dis)	°C
Conf. AI2 high prealr	Config. Analog Input-2 High Pre-Alarm	0 (dis)	300	0 (dis)	°C
Conf. AI2 high reset	Config. Analog Input-2 High Reset	0	300	90	°C
Conf. AI2 high shutd.	Config. Analog Input-2 High Shutdown	0 (dis)	300	0 (dis)	°C
Conf. AI2 control ON	Config. Analog Input-2 Control ON	0 (dis)	300	0 (dis)	°C
Conf. AI2 control OFF	Config. Analog Input-2 Control OFF	0	300	75	°C

Note: dis = disable

Oil Pressure Input Type

This section is used to configure the Oil Pressure sender input.

0-NOT USED: The Oil Pressure input will not be monitored.

1-DIGITAL NC: The Oil pressure input is fed from an engine mounted digital pressure switch. This switch returns a closed signal during low oil pressure conditions (and engine at rest), once oil pressure is established the switch will open.

2-DIGITAL NO: The Oil pressure input is fed from an engine mounted digital pressure switch. This switch returns an open signal during low oil pressure conditions (and engine at rest), once oil pressure is established the switch will close.

3, 4, 5, 6, 7, 8 and 9: Oil pressure input is connected to a resistive type engine mounted oil pressure transducer. If this parameter selected as "**9-USER CONFIGURED**", the user can input the data manually according to the sensor curve.

Temperature Input Type

This section is used to configure the Coolant Temperature sender input.

0-NOT USED: The Coolant Temperature input will not be monitored.

1-DIGITAL NC: The Coolant Temperature input is fed from an engine mounted digital temperature switch. This switch returns a closed signal during low temperature, should the temperature rise above the switch manufacturers trip point the switch contact will open.

2-DIGITAL NO: The Coolant Temperature input is fed from an engine mounted digital temperature switch. This switch returns an open signal during low temperature, should the temperature rise above the switch manufacturers trip point the switch contact will close.

3, 4, 5, 6, 7 and 8: The Coolant Temperature input is connected to a resistive type engine mounted temperature transducer. If this parameter selected as "**8-USER CONFIGURED**", the user can input the data manually according to the sensor curve.

Temperature Sensor Break

Disable: The Coolant Temperature sensor break will not be monitored.

Enable From Safety On (3min. delayed): The Coolant Temperature sensor break will be monitored if the engine runs at least 3 minutes.

Always Enable: The Coolant Temperature sensor break always will be monitored.

Configurable Analog Input-1 Type

This section is used to configure the Configurable Analog Input-1 sender input.

0-NOT USED: The Configurable Analog Input-1 will not be monitored.

1-DIGITAL NC: open for low Configurable Analog Input-1.

2-DIGITAL NO: close for low Configurable Analog Input-1.

3, 4, 5, 6, 7, 8, 9 and 12: The Configurable Analog Input-1 is connected to a resistive type engine mounted level/temperature/pressure transducer. If this parameter selected as "**12-USER CONFIGURED**", the user can input the data manually according to the sensor curve.

10-DAVITEQ (RS485), 11-KUS CLS2 (RS485), 12-MSLL 790 (RS485) and 13-CSFL 790 (RS485): Since these sensors have RS485 communication feature, they are connected to the RS485 port of the device. **Note:** The Configurable Analog Input-1 is not used.

Configurable Analog Input-2 Type

This section is used to configure the Configurable Analog Input-2 sender input.

0-NOT USED: The Configurable Analog Input-2 will not be monitored.

1-DIGITAL NC: open for low Configurable Analog Input-2.

2-DIGITAL NO: close for low Configurable Analog Input-2.

3, 4, 5, 6, 7, 8, 9 and 12: The Configurable Analog Input-2 is connected to a resistive type engine mounted level/temperature/pressure transducer. If this parameter selected as "**12-USER CONFIGURED**", the user can input the data manually according to the sensor curve.

10-DAVITEQ (RS485), 11-KUS CLS2 (RS485), 12-MSLL 790 (RS485) and 13-CSFL 790 (RS485): Since these sensors have RS485 communication feature, they are connected to the RS485 port of the device. **Note:** The Configurable Analog Input-2 is not used.

DAVITEQ (RS485) Sensor Connection:
<i>Brown cable (+24VDC):</i> To battery positive.
<i>White cable (A+):</i> To terminal-43 of Trans-AMF.
<i>Black cable (B-):</i> To terminal-44 of Trans-AMF.
<i>Blue cable (GND):</i> To battery negative.

KUS CLS2 (RS485) Sensor Connection:
<i>Red cable (VCC):</i> To battery positive.
<i>Black cable (GND):</i> To battery negative.
<i>Blue cable (B):</i> To terminal-44 of Trans-AMF.
<i>Yellow cable (A):</i> To terminal-43 of Trans-AMF.

MSLL 790 (RS485) Sensor Connection:
<i>Red cable (VCC):</i> To battery positive.
<i>Black cable (GND):</i> To battery negative.
<i>Green cable (A):</i> To terminal-43 of Trans-AMF.
<i>White cable (B):</i> To terminal-44 of Trans-AMF.

CSFL 790 (RS485) Sensor Connection:
<i>Red cable (5VDC):</i> To battery positive.
<i>Black cable (GND):</i> To battery negative.
<i>Blue cable (A):</i> To terminal-43 of Trans-AMF.
<i>White cable (B):</i> To terminal-44 of Trans-AMF.

SENDER LINEARISATION (<i>Inputs->Sender linearisation</i>)		Min	Max	Default	Unit
Oil pressure sender 1	Oil Pressure Sender Point-1	0	1300	15	R
Oil pressure 1	Oil Pressure Point-1	0.0	30.0	0.0	BAR
Oil pressure sender 2	Oil Pressure Sender Point-2	0	1300	31	R
Oil pressure 2	Oil Pressure Point-2	0.0	30.0	1.0	BAR
Oil pressure sender 3	Oil Pressure Sender Point-3	0	1300	49	R
Oil pressure 3	Oil Pressure Point-3	0.0	30.0	2.0	BAR
Oil pressure sender 4	Oil Pressure Sender Point-4	0	1300	66	R
Oil pressure 4	Oil Pressure Point-4	0.0	30.0	3.0	BAR
Oil pressure sender 5	Oil Pressure Sender Point-5	0	1300	85	R
Oil pressure 5	Oil Pressure Point-5	0.0	30.0	4.0	BAR
Oil pressure sender 6	Oil Pressure Sender Point-6	0	1300	101	R
Oil pressure 6	Oil Pressure Point-6	0.0	30.0	5.0	BAR
Oil pressure sender 7	Oil Pressure Sender Point-7	0	1300	117	R
Oil pressure 7	Oil Pressure Point-7	0.0	30.0	6.0	BAR
Oil pressure sender 8	Oil Pressure Sender Point-8	0	1300	132	R
Oil pressure 8	Oil Pressure Point-8	0.0	30.0	7.0	BAR
Oil pressure sender 9	Oil Pressure Sender Point-9	0	1300	149	R
Oil pressure 9	Oil Pressure Point-9	0.0	30.0	8.0	BAR
Oil pressure sender 10	Oil Pressure Sender Point-10	0	1300	178	R
Oil pressure 10	Oil Pressure Point-10	0.0	30.0	10.0	BAR
Temperature sender 1	Temperature Sender Point-1	0	1300	579	R
Temperature 1	Temperature Point-1	0	300	28	°C
Temperature sender 2	Temperature Sender Point-2	0	1300	404	R
Temperature 2	Temperature Point-2	0	300	35	°C
Temperature sender 3	Temperature Sender Point-3	0	1300	342	R
Temperature 3	Temperature Point-3	0	300	40	°C
Temperature sender 4	Temperature Sender Point-4	0	1300	250	R
Temperature 4	Temperature Point-4	0	300	50	°C
Temperature sender 5	Temperature Sender Point-5	0	1300	179	R
Temperature 5	Temperature Point-5	0	300	60	°C
Temperature sender 6	Temperature Sender Point-6	0	1300	136	R
Temperature 6	Temperature Point-6	0	300	70	°C
Temperature sender 7	Temperature Sender Point-7	0	1300	103	R
Temperature 7	Temperature Point-7	0	300	80	°C
Temperature sender 8	Temperature Sender Point-8	0	1300	77	R
Temperature 8	Temperature Point-8	0	300	90	°C
Temperature sender 9	Temperature Sender Point-9	0	1300	67	R
Temperature 9	Temperature Point-9	0	300	95	°C
Temperature sender 10	Temperature Sender Point-10	0	1300	63	R
Temperature 10	Temperature Point-10	0	300	98	°C



Conf. AI1 sender 1	Configurable Analog Input-1 Sender Point-1	0	1300	10	R
Conf. AI1 value 1	Configurable Analog Input-1 Point-1	0	3000	0	%
Conf. AI1 sender 2	Configurable Analog Input-1 Sender Point-2	0	1300	30	R
Conf. AI1 value 2	Configurable Analog Input-1 Point-2	0	3000	11	%
Conf. AI1 sender 3	Configurable Analog Input-1 Sender Point-3	0	1300	50	R
Conf. AI1 value 3	Configurable Analog Input-1 Point-3	0	3000	22	%
Conf. AI1 sender 4	Configurable Analog Input-1 Sender Point-4	0	1300	70	R
Conf. AI1 value 4	Configurable Analog Input-1 Point-4	0	3000	33	%
Conf. AI1 sender 5	Configurable Analog Input-1 Sender Point-5	0	1300	90	R
Conf. AI1 value 5	Configurable Analog Input-1 Point-5	0	3000	44	%
Conf. AI1 sender 6	Configurable Analog Input-1 Sender Point-6	0	1300	110	R
Conf. AI1 value 6	Configurable Analog Input-1 Point-6	0	3000	55	%
Conf. AI1 sender 7	Configurable Analog Input-1 Sender Point-7	0	1300	130	R
Conf. AI1 value 7	Configurable Analog Input-1 Point-7	0	3000	66	%
Conf. AI1 sender 8	Configurable Analog Input-1 Sender Point-8	0	1300	150	R
Conf. AI1 value 8	Configurable Analog Input-1 Point-8	0	3000	77	%
Conf. AI1 sender 9	Configurable Analog Input-1 Sender Point-9	0	1300	170	R
Conf. AI1 value 9	Configurable Analog Input-1 Point-9	0	3000	88	%
Conf. AI1 sender 10	Configurable Analog Input-1 Sender Point-10	0	1300	190	R
Conf. AI1 value 10	Configurable Analog Input-1 Point-10	0	3000	100	%
Conf. AI2 sender 1	Configurable Analog Input-2 Sender Point-1	0	1300	579	R
Conf. AI2 value 1	Configurable Analog Input-2 Point-1	0	300	28	°C
Conf. AI2 sender 2	Configurable Analog Input-2 Sender Point-2	0	1300	404	R
Conf. AI2 value 2	Configurable Analog Input-2 Point-2	0	300	35	°C
Conf. AI2 sender 3	Configurable Analog Input-2 Sender Point-3	0	1300	342	R
Conf. AI2 value 3	Configurable Analog Input-2 Point-3	0	300	40	°C
Conf. AI2 sender 4	Configurable Analog Input-2 Sender Point-4	0	1300	250	R
Conf. AI2 value 4	Configurable Analog Input-2 Point-4	0	300	50	°C
Conf. AI2 sender 5	Configurable Analog Input-2 Sender Point-5	0	1300	179	R
Conf. AI2 value 5	Configurable Analog Input-2 Point-5	0	300	60	°C
Conf. AI2 sender 6	Configurable Analog Input-2 Sender Point-6	0	1300	136	R
Conf. AI2 value 6	Configurable Analog Input-2 Point-6	0	300	70	°C
Conf. AI2 sender 7	Configurable Analog Input-2 Sender Point-7	0	1300	103	R
Conf. AI2 value 7	Configurable Analog Input-2 Point-7	0	300	80	°C
Conf. AI2 sender 8	Configurable Analog Input-2 Sender Point-8	0	1300	77	R
Conf. AI2 value 8	Configurable Analog Input-2 Point-8	0	300	90	°C
Conf. AI2 sender 9	Configurable Analog Input-2 Sender Point-9	0	1300	67	R
Conf. AI2 value 9	Configurable Analog Input-2 Point-9	0	300	95	°C
Conf. AI2 sender 10	Configurable Analog Input-2 Sender Point-10	0	1300	63	R
Conf. AI2 value 10	Configurable Analog Input-2 Point-10	0	300	98	°C

CONF. INPUT-1 (Inputs->Conf. input-1)		Min	Max	Default	Unit
Dis,user conf.or list	0- Disable 1- User Configured 2- Select From List	0(dis)	2	2	
Polarity	0- Normally Open (Close To Activate) 1- Normally Close (Open To Activate)	0	1	1	
Indication	If User Configured 0- Status 1- Warning Non-Latching 2- Warning Latching 3- Electrical Trip 4- Shutdown	0	4	0	
Activation	If User Configured 0- Active From Starting 1- Active From Safety On 2- Always Active	0	2	2	
Select from list	If Select From List 0-Remote Start On Load 1-Remote Start Off Load 2-Auxiliary Mains Fail 3-Working Calendar Active 4-Simulate Horn Reset Button 5-Simulate Alarm Reset Button 6-Simulate Auto Button 7-Simulate Test Button 8-Simulate Manual Button 9-Simulate Start Button 10-Simulate Stop Button 11-Generator Closed Auxiliary 12-Generator Load Inhibit 13-Mains Closed Auxiliary 14-Mains Load Inhibit 15-Auto Restore Inhibit 16-Auto Start Inhibit 17-Panel Lock 18-Scheduled Runs(Exercise) Inhibited 19-Priority Select 20-Transfer To Generator/Open Mains 21-Transfer To Mains/Open Generator 22-Remote Inhibit 23-Being Found Alive 24-Low Battery 25-Emergency Stop 26-Emergency Stop No-Latching	0	26	25	
Active delay	Input active delay	0	250	0	Sec

Note: dis = disable

CONF. INPUT-2 (Inputs->Conf. Input-2)		Min	Max	Default	Unit
Dis,user conf.or list	0- Disable 1- User Configured 2- Select From List	0(dis)	2	1	
Polarity	0- Normally Open (Close To Activate) 1- Normally Close (Open To Activate)	0	1	0	
Indication	If User Configured 0- Status 1- Warning Non-Latching 2- Warning Latching 3- Electrical Trip 4- Shutdown	0	4	0	
Activation	If User Configured 0- Active From Starting 1- Active From Safety On 2- Always Active	0	2	2	
Select from list	If Select From List 0-Remote Start On Load 1-Remote Start Off Load 2-Auxiliary Mains Fail 3-Working Calendar Active 4-Simulate Horn Reset Button 5-Simulate Alarm Reset Button 6-Simulate Auto Button 7-Simulate Test Button 8-Simulate Manual Button 9-Simulate Start Button 10-Simulate Stop Button 11-Generator Closed Auxiliary 12-Generator Load Inhibit 13-Mains Closed Auxiliary 14-Mains Load Inhibit 15-Auto Restore Inhibit 16-Auto Start Inhibit 17-Panel Lock 18-Scheduled Runs(Exercise) Inhibited 19-Priority Select 20-Transfer To Generator/Open Mains 21-Transfer To Mains/Open Generator 22-Remote Inhibit 23-Being Found Alive 24-Low Battery 25-Sprinkler Mode On Load 26-Sprinkler Mode Off Load	0	26	3	
Active delay	Input active delay	0	250	5	Sec

Note: dis = disable

CONF. INPUT-3 (Inputs->Conf. Input-3)		Min	Max	Default	Unit
Dis,user conf.or list	0- Disable 1- User Configured 2- Select From List	0(dis)	2	1	
Polarity	0- Normally Open (Close To Activate) 1- Normally Close (Open To Activate)	0	1	1	
Indication	If User Configured 0- Status 1- Warning Non-Latching 2- Warning Latching 3- Electrical Trip 4- Shutdown	0	4	4	
Activation	If User Configured 0- Active From Starting 1- Active From Safety On 2- Always Active	0	2	2	
Select from list	If Select From List 0-Remote Start On Load 1-Remote Start Off Load 2-Auxiliary Mains Fail 3-Working Calendar Active 4-Simulate Horn Reset Button 5-Simulate Alarm Reset Button 6-Simulate Auto Button 7-Simulate Test Button 8-Simulate Manual Button 9-Simulate Start Button 10-Simulate Stop Button 11-Generator Closed Auxiliary 12-Generator Load Inhibit 13-Mains Closed Auxiliary 14-Mains Load Inhibit 15-Auto Restore Inhibit 16-Auto Start Inhibit 17-Panel Lock 18-Scheduled Runs(Exercise) Inhibited 19-Priority Select 20-Transfer To Generator/Open Mains 21-Transfer To Mains/Open Generator 22-Remote Inhibit 23-Being Found Alive 24-Low Battery 25-Sprinkler Mode On Load 26-Sprinkler Mode Off Load	0	26	4	
Active delay	Input active delay	0	250	5	Sec

Note: dis = disable

CONF. INPUT-4 (Inputs->Conf. input-4)		Min	Max	Default	Unit
Dis,user conf.or list	0- Disable 1- User Configured 2- Select From List	0(dis)	2	2	
Polarity	0- Normally Open (Close To Activate) 1- Normally Close (Open To Activate)	0	1	0	
Indication	If User Configured 0- Status 1- Warning Non-Latching 2- Warning Latching 3- Electrical Trip 4- Shutdown	0	4	0	
Activation	If User Configured 0- Active From Starting 1- Active From Safety On 2- Always Active	0	2	2	
Select from list	If Select From List 0-Remote Start On Load 1-Remote Start Off Load 2-Auxiliary Mains Fail 3-Working Calendar Active 4-Simulate Horn Reset Button 5-Simulate Alarm Reset Button 6-Simulate Auto Button 7-Simulate Test Button 8-Simulate Manual Button 9-Simulate Start Button 10-Simulate Stop Button 11-Generator Closed Auxiliary 12-Generator Load Inhibit 13-Mains Closed Auxiliary 14-Mains Load Inhibit 15-Auto Restore Inhibit 16-Auto Start Inhibit 17-Panel Lock 18-Scheduled Runs(Exercise) Inhibited 19-Priority Select 20-Transfer To Generator/Open Mains 21-Transfer To Mains/Open Generator 22-Remote Inhibit 23-Being Found Alive 24-Low Battery 25-Low Oil Pressure 26-Low Oil Level	0	26	25	
Active delay	Input active delay	0	250	0	Sec

Note: dis = disable

CONF. INPUT-5 (Inputs->Conf. input-5)		Min	Max	Default	Unit
Dis,user conf.or list	0- Disable 1- User Configured 2- Select From List	0(dis)	2	2	
Polarity	0- Normally Open (Close To Activate) 1- Normally Close (Open To Activate)	0	1	0	
Indication	If User Configured 0- Status 1- Warning Non-Latching 2- Warning Latching 3- Electrical Trip 4- Shutdown	0	4	0	
Activation	If User Configured 0- Active From Starting 1- Active From Safety On 2- Always Active	0	2	2	
Select from list	If Select From List 0-Remote Start On Load 1-Remote Start Off Load 2-Auxiliary Mains Fail 3-Working Calendar Active 4-Simulate Horn Reset Button 5-Simulate Alarm Reset Button 6-Simulate Auto Button 7-Simulate Test Button 8-Simulate Manual Button 9-Simulate Start Button 10-Simulate Stop Button 11-Generator Closed Auxiliary 12-Generator Load Inhibit 13-Mains Closed Auxiliary 14-Mains Load Inhibit 15-Auto Restore Inhibit 16-Auto Start Inhibit 17-Panel Lock 18-Scheduled Runs(Exercise) Inhibited 19-Priority Select 20-Transfer To Generator/Open Mains 21-Transfer To Mains/Open Generator 22-Remote Inhibit 23-Being Found Alive 24-Low Battery 25-High Temperature	0	25	25	
Active delay	Input active delay	0	250	0	Sec

Note: dis = disable

CONF. INPUT-6 (Inputs->Conf. Input-6)		Min	Max	Default	Unit
Dis,user conf.or list	0- Disable 1- User Configured 2- Select From List	0(dis)	2	1	
Polarity	0- Normally Open (Close To Activate) 1- Normally Close (Open To Activate)	0	1	0	
Indication	If User Configured 0- Status 1- Warning Non-Latching 2- Warning Latching 3- Electrical Trip 4- Shutdown	0	4	0	
Activation	If User Configured 0- Active From Starting 1- Active From Safety On 2- Always Active	0	2	2	
Select from list	If Select From List 0-Remote Start On Load 1-Remote Start Off Load 2-Auxiliary Mains Fail 3-Working Calendar Active 4-Simulate Horn Reset Button 5-Simulate Alarm Reset Button 6-Simulate Auto Button 7-Simulate Test Button 8-Simulate Manual Button 9-Simulate Start Button 10-Simulate Stop Button 11-Generator Closed Auxiliary 12-Generator Load Inhibit 13-Mains Closed Auxiliary 14-Mains Load Inhibit 15-Auto Restore Inhibit 16-Auto Start Inhibit 17-Panel Lock 18-Scheduled Runs(Exercise) Inhibited 19-Priority Select 20-Transfer To Generator/Open Mains 21-Transfer To Mains/Open Generator 22-Remote Inhibit 23-Being Found Alive 24-Low Battery 25-Sprinkler Mode On Load 26-Sprinkler Mode Off Load	0	26	7	
Active delay	Input active delay	0	250	5	Sec

Note: dis = disable

CONF. INPUT-7 (Inputs->Conf. input-7)		Min	Max	Default	Unit
Input type	0- Disable 1- User Configured (Digital) 2- Select From List (Digital) 3- Cabin Temperature (Anolog)	0(dis)	3	3	
Polarity	If Input Type is Digital 0- Normally Open (Close To Activate) 1- Normally Close (Open To Activate)	0	1	0	
Indication	If Input Type is User Configured 0- Status 1- Warning Non-Latching 2- Warning Latching 3- Electrical Trip 4- Shutdown	0	4	0	
Activation	If Input Type is User Configured 0- Active From Starting 1- Active From Safety On 2- Always Active	0	2	2	
Select from list	If Input Type is Select From List 0-Remote Start On Load 1-Remote Start Off Load 2-Auxiliary Mains Fail 3-Working Calendar Active 4-Simulate Horn Reset Button 5-Simulate Alarm Reset Button 6-Simulate Auto Button 7-Simulate Test Button 8-Simulate Manual Button 9-Simulate Start Button 10-Simulate Stop Button 11-Generator Closed Auxiliary 12-Generator Load Inhibit 13-Mains Closed Auxiliary 14-Mains Load Inhibit 15-Auto Restore Inhibit 16-Auto Start Inhibit 17-Panel Lock 18-Scheduled Runs(Exercise) Inhibited 19-Priority Select 20-Transfer To Generator/Open Mains 21-Transfer To Mains/Open Generator 22-Remote Inhibit 23-Being Found Alive 24-Low Battery 25-Sprinkler Mode On Load 26-Sprinkler Mode Off Load	0	26	8	
Active delay	Input active delay (If Input Type is Digital)	0	250	5	Sec
Cabin temp.low prealr	Cabin temperature low prealarm	-50(dis)	100	dis	°C
Cabin temp.low reset	Cabin temperature low prealarm reset	-50	100	0	°C
Cabin temp.low shutd.	Cabin temperature low shutdown	-50(dis)	100	dis	°C
Cabin temp.high preal	Cabin temperature high prealarm reset	-50(dis)	100	dis	°C
Cabin temp.high reset	Cabin temperature high prealarm	-50	100	0	°C
Cabin temp.high shutd	Cabin temperature high shutdown	-50(dis)	100	dis	°C

Note: dis = disable

CONF. EXP. INPUT-1 (Inputs->Conf. exp. input-1)		Min	Max	Default	Unit
Dis,user conf.or list	0- Disable 1- User Configured 2- Select From List	0(dis)	2	1	
Hardware type	0-> -Ve (Switched To Battery -) 1-> +Ve (Switched To Battery +)	0	1	0	
Polarity	0- Normally Open (Close To Activate) 1- Normally Close (Open To Activate)	0	1	0	
Indication	If User Configured 0- Status 1- Warning Non-Latching 2- Warning Latching 3- Electrical Trip 4- Shutdown	0	4	0	
Activation	If User Configured 0- Active From Starting 1- Active From Safety On 2- Always Active	0	2	2	
Select from list	If Select From List 2-Auxiliary Mains Fail 3-Working Calendar Active 4-Simulate Horn Reset Button 5-Simulate Alarm Reset Button 6-Simulate Auto Button 7-Simulate Test Button 8-Simulate Manual Button 9-Simulate Start Button 10-Simulate Stop Button 11-Generator Closed Auxiliary 12-Generator Load Inhibit 13-Mains Closed Auxiliary 14-Mains Load Inhibit 15-Auto Restore Inhibit 16-Auto Start Inhibit 17-Panel Lock 18-Scheduled Runs(Exercise) Inhibited 19-Priority Select 20-Transfer To Generator/Open Mains 21-Transfer To Mains/Open Generator	2	21	2	
Active delay	Input active delay	0	250	5	Sec

CONF. EXP. INPUT-2 (Inputs->Conf. exp. input-2)		Min	Max	Default	Unit
Dis,user conf.or list	The same as Expansion Config. Input-1 options	0(dis)	2	1	
Hardware type	The same as Expansion Config. Input-1 options	0	1	0	
Polarity	The same as Expansion Config. Input-1 options	0	1	0	
Indication	The same as Expansion Config. Input-1 options	0	4	0	
Activation	The same as Expansion Config. Input-1 options	0	2	2	
Select from list	The same as Expansion Config. Input-1 options	2	21	2	
Active delay	Input active delay	0	250	5	Sec

CONF. EXP. INPUT-3 (Inputs->Conf. exp. input-3)		Min	Max	Default	Unit
Dis,user conf.or list	The same as Expansion Config. Input-1 options	0(dis)	2	1	
Hardware type	The same as Expansion Config. Input-1 options	0	1	0	
Polarity	The same as Expansion Config. Input-1 options	0	1	0	
Indication	The same as Expansion Config. Input-1 options	0	4	0	
Activation	The same as Expansion Config. Input-1 options	0	2	2	
Select from list	The same as Expansion Config. Input-1 options	2	21	2	
Active delay	Input active delay	0	250	5	Sec

CONF. EXP. INPUT-4 (Inputs->Conf. exp. input-4)		Min	Max	Default	Unit
Dis,user conf.or list	The same as Expansion Config. Input-1 options	0(dis)	2	1	
Hardware type	The same as Expansion Config. Input-1 options	0	1	0	
Polarity	The same as Expansion Config. Input-1 options	0	1	0	
Indication	The same as Expansion Config. Input-1 options	0	4	0	
Activation	The same as Expansion Config. Input-1 options	0	2	2	
Select from list	The same as Expansion Config. Input-1 options	2	21	2	
Active delay	Input active delay	0	250	5	Sec

CONF. EXP. INPUT-5 (Inputs->Conf. exp. input-5)		Min	Max	Default	Unit
Dis,user conf.or list	The same as Expansion Config. Input-1 options	0(dis)	2	1	
Hardware type	The same as Expansion Config. Input-1 options	0	1	0	
Polarity	The same as Expansion Config. Input-1 options	0	1	0	
Indication	The same as Expansion Config. Input-1 options	0	4	0	
Activation	The same as Expansion Config. Input-1 options	0	2	2	
Select from list	The same as Expansion Config. Input-1 options	2	21	2	
Active delay	Input active delay	0	250	5	Sec

CONF. EXP. INPUT-6 (Inputs->Conf. exp. input-6)		Min	Max	Default	Unit
Dis,user conf.or list	The same as Expansion Config. Input-1 options	0(dis)	2	1	
Hardware type	The same as Expansion Config. Input-1 options	0	1	0	
Polarity	The same as Expansion Config. Input-1 options	0	1	0	
Indication	The same as Expansion Config. Input-1 options	0	4	0	
Activation	The same as Expansion Config. Input-1 options	0	2	2	
Select from list	The same as Expansion Config. Input-1 options	2	21	2	
Active delay	Input active delay	0	250	5	Sec

CONF. EXP. INPUT-7 (Inputs->Conf. exp. input-7)		Min	Max	Default	Unit
Dis,user conf.or list	The same as Expansion Config. Input-1 options	0(dis)	2	1	
Hardware type	The same as Expansion Config. Input-1 options	0	1	0	
Polarity	The same as Expansion Config. Input-1 options	0	1	0	
Indication	The same as Expansion Config. Input-1 options	0	4	0	
Activation	The same as Expansion Config. Input-1 options	0	2	2	
Select from list	The same as Expansion Config. Input-1 options	2	21	2	
Active delay	Input active delay	0	250	5	Sec

CONF. EXP. INPUT-8 (Inputs->Conf. exp. input-8)		Min	Max	Default	Unit
Dis,user conf.or list	The same as Expansion Config. Input-1 options	0(dis)	2	1	
Hardware type	The same as Expansion Config. Input-1 options	0	1	0	
Polarity	The same as Expansion Config. Input-1 options	0	1	0	
Indication	The same as Expansion Config. Input-1 options	0	4	0	
Activation	The same as Expansion Config. Input-1 options	0	2	2	
Select from list	The same as Expansion Config. Input-1 options	2	21	2	
Active delay	Input active delay	0	250	5	Sec

CONFIGURABLE INPUTS SELECTIONS

0 REMOTE START ON LOAD

In AUTO mode, if one of the configurable inputs are selected as 0 (Remote Start On Load), the unit doesn't perform the mains failure control in order to start the generator. In AUTO mode, if one of the configurable inputs are selected as 0 (Remote Start On Load) and this input is active, then the unit will perform the start sequence and transfer load to the generator. If the input is passive, the unit will perform the stop sequence.

Note: dis = disable

1 REMOTE START OFF LOAD

If this input is active, operation will be similar to the 'Remote Start On Load' function except that the generator will not be instructed to take the load. This function can be used where an engine only run is required e.g. for exercise.

2 AUXILIARY MAINS FAIL

The unit will monitor the incoming single or three phase supply for Over Voltage, Under Voltage, Over Frequency or Under Frequency. It may be required to monitor a different mains supply or some aspect of the incoming mains not monitored by the unit. If the devices providing this additional monitoring are connected to operate this input, the unit will operate as if the incoming mains supply has fallen outside of limits, the generator will be instructed to start and take load. Removal of the input signal will cause the unit to act if the mains has returned to within limits.

3 WORKING CALENDAR ACTIVE

If this input is active, the unit will monitor the working calendar parameters. If this input is passive, the unit will not monitor the working calendar parameters.

4 SIMULATE HORN RESET BUTTON

This input mimics the operation of the 'Horn Reset' button and is used to provide a remotely located Horn Reset push button.

5 SIMULATE ALARM RESET BUTTON

This input mimics the operation of the 'Alarm Reset' button and is used to provide a remotely located Alarm Reset push button.

6 SIMULATE AUTO BUTTON

This input mimics the operation of the 'Auto' button and is used to provide a remotely located Auto mode push button.

7 SIMULATE TEST BUTTON

This input mimics the operation of the 'Test' button and is used to provide a remotely located Test mode push button.

8 SIMULATE MANUAL BUTTON

This input mimics the operation of the 'Manual' button and is used to provide a remotely located Manual mode push button.

9 SIMULATE START BUTTON

This input mimics the operation of the 'Start' button and is used to provide a remotely located start push button.

10 SIMULATE STOP BUTTON

This input mimics the operation of the 'Stop' button and is used to provide a remotely located Stop push button.

11 GENERATOR CLOSED AUXILIARY

This input is used to provide feedback to allow the unit to give true indication of the contactor or circuit breaker switching status. It should be connected to the generator load switching device auxiliary contact.

12 GENERATOR LOAD INHIBIT

This input is used to prevent the unit from loading the generator. If the generator is already on load, activating this input will cause the unit to unload the generator. Removing the input will allow the generator to be loaded again. **Note:** This input only operates to control the generator-switching device if the unit load switching logic is attempting to load the generator. It will not control the generator-switching device when the mains is on load.

13 MAINS CLOSED AUXILIARY

This input is used to provide feedback to allow the unit to give true indication of the contactor or circuit breaker switching status. It should be connected to the generator load switching device auxiliary contact.

14 MAINS LOAD INHIBIT

This input is used to prevent the unit from loading the mains supply. If the mains supply is already on load, activating this input will cause the unit to unload the mains supply. Removing the input will allow the mains to be loaded again. **Note:** This input only operates to control the mains-switching device if the unit load switching logic is attempting to load the mains. It will not control the mains-switching device when the generator is on load.

15 AUTO RESTORE INHIBIT

When module in the AUTO mode. In the event of a remote start or mains failure, the generator will be instructed to start and take load. On removal of the remote start signal or mains return, the module will continue to run the generator on load until this input is removed. Once the input is removed the unit will transfer the load back to the mains supply and follow a normal generator stop sequence. This input allows the module to be fitted as part of a system where the manual restoration to mains is controlled remotely or by an automated system.

16 AUTO START INHIBIT

This input is used to provide an over-ride function to prevent the unit from starting the generator in the event of a remote start or mains out of limits condition occurring. If this input is active and a remote start signal or mains failure occurs the unit will not give a start command to the generator. If this input signal is then removed, the unit will operate as if a remote start or mains failure has occurred, starting and loading the generator. This function can be used to give an 'AND' function so that a generator will only be called to start if the mains fails and another condition exists which requires the generator to run. If the 'Auto Start Inhibit' signal become active once more it will be ignored until the unit has returned the mains supply on load and shutdown.

17 PANEL LOCK

This input is used to provide security to the installation. If the panel lock input is active, the unit will not respond to operation of the mode select or start buttons. This allows the unit to be placed into a specific mode (such as Auto) and then secured. The operation of the unit is not affected and the operator will still be able to view the various instrumentation pages etc. **Note:** External control sources (i.e. Simulate Start Button) are not affected by the panel lock input and will continue to operate normally.

18 SCHEDULED RUNS(EXERCISE) INHIBITED

This input is used to prevent the generator from starting in the event of a programmed scheduled (exercise) run occurring. While the input is active no scheduled runs will occur. If the input is active when a schedule run is called for, and is removed during the running period the gen-set will start and complete any remaining scheduled running time.

19 PRIORITY SELECT

This input is used to determine the generator that is working at dual set application.

20 TRANSFER TO GENERATOR/OPEN MAINS

This input is used to transfer the load to the generator when running in Manual mode.

21 TRANSFER TO MAINS/OPEN GENERATOR

This input is used to transfer the load to the mains supply when running in Manual mode.

22 REMOTE INHIBIT

In AUTO mode, if one of the configurable inputs are selected as 22 (Remote Inhibit) and this input is active, the module will inhibit the generator from starting. In the other hand, if this input is active while the generator was starting, the module will stop the generator.

23 BEING FOUND ALIVE

When this input is active, controlling the engine remotely is not possible.

24 LOW BATTERY

If this input is active when the unit is in AUTO mode and if mains is not okay, the unit will perform the start sequence and transfer load to the generator.

25 EMERGENCY STOP (FOR CONFIGURABLE INPUT-1)

This input is used as the emergency stop input.

25 SPRINKLER MODE ON LOAD (FOR CONFIGURABLE INPUT-2,3,6,7)

This input is used as the sprinkler mode input. When this input is active, all alarms will change to warnings, except overspeed and emergency stop.

25 LOW OIL PRESSURE (FOR CONFIGURABLE INPUT-4)

This input is used as the oil pressure failure input. It will be checked while starting or stopping attempts.

25 HIGH TEMPERATURE (FOR CONFIGURABLE INPUT-5)

This input is used as the temperature failure input.

26-LOW OIL LEVEL (FOR CONFIGURABLE INPUT-4)

This input is used as the oil pressure failure input. It won't be checked while starting or stopping attempts.

26 EMERGENCY STOP NO-LATCHING (FOR CONFIGURABLE INPUT-1)

This input is used as the non-latching emergency stop input.

26 SPRINKLER MODE OFF LOAD (FOR CONFIGURABLE INPUT-2,3,6,7)

This input is used as the sprinkler mode input. When this input is active, all alarms will change to warnings, except overspeed and emergency stop. Also when this input is active, the generator breaker will not be active.

4.2.6 Outputs

CONF. OUTPUT-1 (Outputs->Conf. output-1)		Min	Max	Default	Unit
Polarity	0- Normally Open (Close To Activate) 1- Normally Close (Open To Activate)	0	1	0	
Function	0-NOT USED 1-AIR FLAP CONTROL 2-ALARM RESET 3-AUDIBLE ALARM 4-AUTO START INHIBIT 5-AUXILIARY MAINS FAILURE 6-BATTERY HIGH VOLTAGE 7-BATTERY LOW VOLTAGE 8-CALLING FOR SCHEDULED RUN(EXERCISE) 9-CAN ECU POWER 10-CAN ECU STOP 11-CHARGE ALTERNATOR FAILURE 12-COMMON ALARM 13-COMMON ELECTRICAL TRIP ALARM 14-COMMON SHUTDOWN ALARM 15-COMMON WARNING ALARM 16-COOLING FAN AFTER START 17-COOLING FAN AFTER STOP 18-COOLANT TEMPERATURE HIGH PRE-ALARM 19-COOLANT TEMPERATURE HIGH SHUTDOWN 20-COOLING DOWN TIMER IN PROGRESS 21-CRANK RELAY ENERGISED 22-DELAYED ALARMS ACTIVE 23-DIGITAL INPUT1 ALARM 24-DIGITAL INPUT2 ALARM 25-DIGITAL INPUT3 ALARM 26-DIGITAL INPUT4 ALARM 27-DIGITAL INPUT5 ALARM 28-DIGITAL INPUT6 ALARM 29-DIGITAL INPUT7 ALARM 30-EXPANSION INPUT1 ALARM 31-EXPANSION INPUT2 ALARM 32-EXPANSION INPUT3 ALARM 33-EXPANSION INPUT4 ALARM 34-EXPANSION INPUT5 ALARM 35-EXPANSION INPUT6 ALARM 36-EXPANSION INPUT7 ALARM 37-EXPANSION INPUT8 ALARM 38-EARTH FAULT 39-EMERGENCY STOP 40-FAIL TO START ALARM 41-FAIL TO STOP ALARM 42-CONF. A11 CONTROL 43-FUEL RELAY ENERGISED 44-GAS ENGINE IGNITION OUTPUT 45-GENERATOR AT REST 46-GENERATOR AVAILABLE 47-GENERATOR CLOSED AUXILIARY 48-GENERATOR FAILED TO CLOSE 49-GENERATOR FAILED TO OPEN 50-GENERATOR HIGH FREQUENCY PRE-ALARM 51-GENERATOR HIGH FREQUENCY SHUTDOWN 52-GENERATOR HIGH VOLTAGE PRE-ALARM 53-GENERATOR HIGH VOLTAGE SHUTDOWN 54-GENERATOR LOAD INHIBIT 55-GENERATOR LOW FREQUENCY PRE-ALARM 56-GENERATOR LOW FREQUENCY SHUTDOWN 57-GENERATOR LOW VOLTAGE PRE-ALARM 58-GENERATOR LOW VOLTAGE SHUTDOWN 59-GENERATOR STOPPING 60-GENERATOR OPEN BREAKER 61-HORN OUTPUT LATCHED 62-HORN OUTPUT PULSED 63-LAMP TEST 64-CONF. A12 CONTROL 65-LOSS OF MAGNETIC PICK-UP SPEED SIGNAL 66-LOW TEMPERATURE 67-MAINTENANCE DUE ALARM 68-MAINS CLOSED AUXILIARY 69-MAINS FAILED TO CLOSE 70-MAINS FAILED TO OPEN 71-MAINS FAILURE 72-MAINS HIGH FREQUENCY 73-MAINS HIGH VOLTAGE 74-MAINS LOAD INHIBIT 75-MAINS LOW FREQUENCY 76-MAINS LOW VOLTAGE 77-MAINS OPEN BREAKER 78-NO LOADING COMMAND 79-OIL PRESSURE LOW PRE-ALARM 80-OIL PRESSURE LOW SHUTDOWN 81-CONF. A11 HIGH PREA 82-CONF. A11 HIGH SHUT 83-OVER CURRENT PRE-ALARM 84-OVER CURRENT 85-OVER POWER PRE-ALARM 86-OVER POWER SHUTDOWN 87-OVERSPD PRE-ALARM 88-OVERSPD SHUTDOWN 89-PANEL LOCK 90-PRE-HEAT(during preheat timer) 91-PRE-HEAT(until end of cranking) 92-PRE-HEAT(until end of warming) 93-PRE-HEAT(until end safety on) 94-REMOTE START PRESENT 95-REMOTE STOP DELAY IN PROGRESS 96-SHORT CIRCUIT 97-SMOKE LIMITING 98-STARTING ALARM 99-STARTING ALARMS ARMED 100-STOP RELAY ENERGISED 101-SYSTEM IN AUTO MODE 102-SYSTEM IN MANUAL MODE 103-SYSTEM IN STOP MODE 104-SYSTEM IN TEST MODE 105-UNDER CURRENT PRE-ALARM 106-UNDER CURRENT 107-UNDER POWER PRE-ALARM 108-UNDER POWER SHUTDOWN 109-UNDERSPEED PRE-ALARM 110-UNDERSPEED SHUTDOWN 111-WAITING FOR GENERATOR 112-DUAL COMMUNICATION ERROR 113-LOAD SUPPLY FROM GENERATOR 114-LOAD SUPPLY FROM MAINS 115-CONFIGURABLE ANALOG INPUT 1 LOW PRE-ALARM 116-CONFIGURABLE ANALOG INPUT 1 LOW SHUTDOWN 117-CONFIGURABLE ANALOG INPUT 2 LOW PRE-ALARM 118-CONFIGURABLE ANALOG INPUT 2 LOW SHUTDOWN 119-CONFIGURABLE ANALOG INPUT 2 HIGH PRE-ALARM 120-CONFIGURABLE ANALOG INPUT 2 HIGH SHUTDOWN 121-CHOKE ACTIVE 122-REMOTE CONTROL ACTIVE 123-REVERSE POWER 124-CABIN TEMPERATURE LOW PRE-ALARM 125-CABIN TEMPERATURE LOW SHUTDOWN 126-CABIN TEMPERATURE HIGH PRE-ALARM 127-CABIN TEMPERATURE HIGH SHUTDOWN 128-HEATER CONTROL 129-REMOTE OUTPUT 130-UNBALANCE LOAD 131-WATER PUMP 132-RESERVED 133-RESERVED 134-RESERVED 135-RESERVED 136-SYNCHRON POSITION 137-OVER LOAD STEP 1 138-OVER LOAD STEP 2	0	138	43	

CONF. OUTPUT-2 (Outputs->Conf. output-2)		Min	Max	Default	Unit
Polarity	0- Normally Open (Close To Activate) 1- Normally Close (Open To Activate)	0	1	0	
Function	The same as Configurable Output-1 options	0	138	21	

CONF. OUTPUT-3 (Outputs->Conf. output-3)		Min	Max	Default	Unit
Polarity	0- Normally Open (Close To Activate) 1- Normally Close (Open To Activate)	0	1	0	
Function	The same as Configurable Output-1 options	0	138	62	

CONF. OUTPUT-4 (Outputs->Conf. output-4)		Min	Max	Default	Unit
Polarity	0- Normally Open (Close To Activate) 1- Normally Close (Open To Activate)	0	1	0	
Function	The same as Configurable Output-1 options	0	138	9	

CONF. OUTPUT-5 (Outputs->Conf. output-5)		Min	Max	Default	Unit
Polarity	0- Normally Open (Close To Activate) 1- Normally Close (Open To Activate)	0	1	0	
Function	The same as Configurable Output-1 options	0	138	10	

CONF. OUTPUT-6 (Outputs->Conf. output-6)		Min	Max	Default	Unit
Polarity	0- Normally Open (Close To Activate) 1- Normally Close (Open To Activate)	0	1	0	
Function	The same as Configurable Output-1 options	0	138	12	

CONF. EXP. OUTPUT-1 (Outputs->Conf. exp. output-1)		Min	Max	Default	Unit
Polarity	0- Normally Open (Close To Activate) 1- Normally Close (Open To Activate)	0	1	0	
Function	The same as Configurable Output-1 options	0	138	12	

CONF. EXP. OUTPUT-2 (Outputs->Conf. exp. output-2)		Min	Max	Default	Unit
Polarity	0- Normally Open (Close To Activate) 1- Normally Close (Open To Activate)	0	1	0	
Function	The same as Configurable Output-1 options	0	138	12	

CONF. EXP. OUTPUT-3 (Outputs->Conf. exp. output-3)		Min	Max	Default	Unit
Polarity	0- Normally Open (Close To Activate) 1- Normally Close (Open To Activate)	0	1	0	
Function	The same as Configurable Output-1 options	0	138	12	

CONF. EXP. OUTPUT-4 (Outputs->Conf. exp. output-4)		Min	Max	Default	Unit
Polarity	0- Normally Open (Close To Activate) 1- Normally Close (Open To Activate)	0	1	0	
Function	The same as Configurable Output-1 options	0	138	12	

CONF. EXP. OUTPUT-5 (Outputs->Conf. exp. output-5)		Min	Max	Default	Unit
Polarity	0- Normally Open (Close To Activate) 1- Normally Close (Open To Activate)	0	1	0	
Function	The same as Configurable Output-1 options	0	138	12	

CONF. EXP. OUTPUT-6 (Outputs->Conf. exp. output-6)		Min	Max	Default	Unit
Polarity	0- Normally Open (Close To Activate) 1- Normally Close (Open To Activate)	0	1	0	
Function	The same as Configurable Output-1 options	0	138	12	

CONF. EXP. OUTPUT-7 (Outputs->Conf. exp. output-7)		Min	Max	Default	Unit
Polarity	0- Normally Open (Close To Activate) 1- Normally Close (Open To Activate)	0	1	0	
Function	The same as Configurable Output-1 options	0	138	12	

CONF. EXP. OUTPUT-8 (Outputs->Conf. exp. output-8)		Min	Max	Default	Unit
Polarity	0- Normally Open (Close To Activate) 1- Normally Close (Open To Activate)	0	1	0	
Function	The same as Configurable Output-1 options	0	138	12	

CONFIGURABLE OUTPUTS SELECTIONS

0 NOT USED

Output is not used

1 AIR FLAP CONTROL

Normally used to control an air flap, this output becomes active upon an Engine shutdown failure situation. Inactive when the set has come to rest.

2 ALARM RESET

The output indicates that an alarm reset being performed. Once the alarm reset has been completed, the output become inactive again. The output could be used to give an external reset signal to external systems.

3 AUDIBLE ALARM

The output indicates that the internal sounder is operating. It may be use for external sounder.

4 AUTO START INHIBIT

This output indicates that a digital input that has been configured as 'auto start inhibit' is active.

5 AUXILIARY MAINS FAILURE

This output indicates that a digital input that has been configured as 'auxiliary mains failure' is active.

6 BATTERY HIGH VOLTAGE

This output indicates that a battery high voltage alarm has occurred.

7 BATTERY LOW VOLTAGE

This output indicates that a battery low voltage alarm has occurred.

8 CALLING FOR SCHEDULED RUN(EXERCISE)

This output indicates that a scheduled run(exercise) has been called for. If the unit is in the 'auto' and mains okay, the unit will change mode to 'test' and the generator will run if no shutdown alarms are present.

9 CAN ECU POWER

This output normally used to turn on the ECU (sometimes via an external slave relay). Some engine ECUs are permanently powered in which case the ECU Power output is used to give input to a Run (or similarly named) input on the ECU.

10 CAN ECU STOP

This output used to give input to a Stop (or similarly named) input on the ECU. This is used as a backup stop system should the ECU Data link fail. In this instance, it is not possible to stop the engine using a data command as the link is not operative. As a backup, the STOP signal is given to the engine via a separate hardwired connection.

11 CHARGE ALTERNATOR FAILURE

This output indicates that a charging alternator failure has occurred.

12 COMMON ALARM

This output indicates that a warning, electrical trip or shutdown alarm has been activated.

13 COMMON ELECTRICAL TRIP ALARM

This output indicates that an electrical trip alarm has been activated. This output can only be reset by removal of the fault and by then pressing the RESET button.

14 COMMON SHUTDOWN ALARM

This output indicates that a shutdown alarm has been activated. This output can only be reset by removal of the fault and by then pressing the RESET button or by using an external 'alarm reset' input.

15 COMMON WARNING ALARM

This output indicates that a warning alarm has been activated. This output is normally self-resetting on removal of the fault.

16 COOLING FAN AFTER START

This output should energise as soon as engine has started so the fan should be running when the engine is running. This output should continue to operate for Cooling Fan Time parameter after engine has stopped.

17 COOLING FAN AFTER STOP

This output indicates that can be made to energise for Cooling Fan Time parameter after the engine shuts down (to run an electric cooling fan on the radiator).

18 COOLANT TEMPERATURE HIGH PRE-ALARM

This output indicates that a high engine coolant temperature warning (pre-alarm) has occurred.

19 COOLANT TEMPERATURE HIGH SHUTDOWN

This output indicates that a high engine coolant temperature shutdown has occurred.

20 COOLING DOWN TIMER IN PROGRESS

This output source will be active when the cooling off-load timer is running.

21 CRANK RELAY ENERGISED

The output mimics the operation of the crank relay. Can be used to control external logic circuitry.

22 DELAYED ALARMS ACTIVE

The output indicates that the delayed alarms now enabled. Can be used to control external logic circuitry.

23 DIGITAL INPUT1 ALARM

This output indicates that digital input 1 alarm has occurred.

24 DIGITAL INPUT2 ALARM

This output indicates that digital input 2 alarm has occurred.

25 DIGITAL INPUT3 ALARM

This output indicates that digital input 3 alarm has occurred.

26 DIGITAL INPUT4 ALARM

This output indicates that digital input 4 alarm has occurred.

27 DIGITAL INPUT5 ALARM

This output indicates that digital input 5 alarm has occurred.

28 DIGITAL INPUT6 ALARM

This output indicates that digital input 6 alarm has occurred.

29 DIGITAL INPUT7 ALARM

This output indicates that digital input 7 alarm has occurred.

30 EXPANSION CONFIGURABLE INPUT1 ALARM

This output indicates that expansion configurable input 1 alarm has occurred.

31 EXPANSION CONFIGURABLE INPUT2 ALARM

This output indicates that expansion configurable input 2 alarm has occurred.

32 EXPANSION CONFIGURABLE INPUT3 ALARM

This output indicates that expansion configurable input 3 alarm has occurred.

33 EXPANSION CONFIGURABLE INPUT4 ALARM

This output indicates that expansion configurable input 4 alarm has occurred.

34 EXPANSION CONFIGURABLE INPUT5 ALARM

This output indicates that expansion configurable input 5 alarm has occurred.

35 EXPANSION CONFIGURABLE INPUT6 ALARM

This output indicates that expansion configurable input 6 alarm has occurred.

36 EXPANSION CONFIGURABLE INPUT7 ALARM

This output indicates that expansion configurable input 7 alarm has occurred.

37 EXPANSION CONFIGURABLE INPUT8 ALARM

This output indicates that expansion configurable input 8 alarm has occurred.

38 EARTH FAULT

This output indicates that the unit has detected that an earth fault exists on the generator output.

39 EMERGENCY STOP

This output indicates that an emergency stop alarm has occurred.

40 FAIL TO START ALARM

This output indicates that the engine has not started after the specified number of attempts.

41 FAIL TO STOP ALARM

This output indicates that the generator has failed to stop within the selected time

42 CONFIGURABLE ANALOG INPUT-1 CONTROL

Becomes active when the Analog Input-1 falls below the "ANALOG INPUT-1 ON" setting. If the output is already active it will become inactive when the Analog Input-1 is above the "ANALOG INPUT-1 OFF" setting.

43 FUEL RELAY ENERGISED

The output mimics the operation of the fuel relay. It can be used to control external logic circuitry.

44 GAS ENGINE IGNITION OUTPUT

With the engaging of the starter the ignition delay is started. If the 'minimum ignition speed' is reached after expiry of this time, the configurable relay output 'ignition' is set. When the necessary engine shutdown process, firstly gas valve is de-energised. Then ignition output is de-energised that after 5 seconds when the engine speed become lower than 'minimum ignition speed'

45 GENERATOR AT REST

The output indicates that the generator is not running.

46 GENERATOR AVAILABLE

This output indicates when the generator is ready to accept load, i.e. after safety on and warm up timers have timed out.

47 GENERATOR CLOSED AUXILIARY

This output indicates that a digital input that has been configured as 'generator closed auxiliary' is active.

48 GENERATOR FAILED TO CLOSE

This output source has intended to be used to indicate a failure of the generator contactor or breaker. It can only be used if the unit is configured to use 'generator closed auxiliary' feedback.

49 GENERATOR FAILED TO OPEN

This output source has intended to be used to indicate a failure of the generator contactor or breaker. It can only be used if the unit is configured to use 'generator closed auxiliary' feedback.

50 GENERATOR HIGH FREQUENCY PRE-ALARM

This output indicates that a generator high frequency warning (pre-alarm) has occurred.

51 GENERATOR HIGH FREQUENCY SHUTDOWN

This output indicates that a generator high frequency shutdown has occurred.

52 GENERATOR HIGH VOLTAGE PRE-ALARM

This output indicates that a generator high voltage warning (pre-alarm) has occurred.

53 GENERATOR HIGH VOLTAGE SHUTDOWN

This output indicates that a generator high voltage shutdown has occurred.

54 GENERATOR LOAD INHIBIT

This output indicates that a digital input has been configured as 'generator load inhibit' is active.

55 GENERATOR LOW FREQUENCY PRE-ALARM

This output indicates that a generator low frequency warning (pre-alarm) has occurred.

56 GENERATOR LOW FREQUENCY SHUTDOWN

This output indicates that a generator low frequency shutdown has occurred.

57 GENERATOR LOW VOLTAGE PRE-ALARM

This output indicates that a generator low voltage warning (pre-alarm) has occurred.

58 GENERATOR LOW VOLTAGE SHUTDOWN

This output indicates that a generator low voltage shutdown has occurred.

59 GENERATOR STOPPING

This output indicates that the engine has been instructed to stop but has not come to rest.

60 GENERATOR OPEN BREAKER

This output used to control the load switching device. For Details see: "BREAKERS Page" section.

61 HORN OUTPUT LATCHED

This output indicates that the latched horn alarm has occurred.

62 HORN OUTPUT PULSED

This output indicates that the pulsed horn alarm has occurred.

63 LAMP TEST

This output indicates that the module is performing a lamp test. Once the lamp test completed, the output will become inactive again. The output can be used to feed a lamp test on external modules or panel lamps.

64 CONFIGURABLE ANALOG INPUT-2 CONTROL

Becomes active when the Analog Input-2 falls below the "ANALOG INPUT-2 ON" setting. If the output is already active it will become inactive when the Analog Input-2 is above the "ANALOG INPUT-2 OFF" setting.

65 LOSS OF MAGNETIC PICK-UP SPEED SIGNAL

This output indicates that the magnetic pick up signal is not sufficient to be used by the unit for speed monitoring. The alarm can only operate if the speed signal fails to appear during cranking. It is disabled if 'multiple attempts to engage' is selected. If the MPU fails during engine running this would result in an under speed alarm.

66 LOW TEMPERATURE

This output indicates that a low temperature warning has occurred.

67 MAINTENANCE DUE ALARM

This output indicates that the generator is now due for maintenance either because it has used all the available running hours or the periodic maintenance time has expired. To clear the output a maintenance reset must be performed.

68 MAINS CLOSED AUXILIARY

This output indicates that a digital input that has been configured as 'mains closed auxiliary' is active.

69 MAINS FAILED TO CLOSE

This output source has intended to be used to indicate a failure of the mains contactor or breaker. It can only be used if the unit is configured to use 'mains closed auxiliary' feedback.

70 MAINS FAILED TO OPEN

This output source has intended to be used to indicate a failure of the mains contactor or breaker. It can only be used if the unit is configured to use 'mains closed auxiliary' feedback.

71 MAINS FAILURE

This output indicates that the unit has sensed that a failure of the incoming AC mains supply. This output will become active whenever the mains voltage or frequency goes out of limits, or if the auxiliary mains failure input active (if used) and the mains transient timer has expired.

72 MAINS HIGH FREQUENCY

This output indicates that the unit has sensed that the incoming AC mains supply frequency has exceeded the frequency limit setting.

73 MAINS HIGH VOLTAGE

This output indicates that the unit has sensed that the incoming AC mains supply voltage has exceeded the voltage limit setting.

74 MAINS LOAD INHIBIT

This output indicates that a digital input has been configured as 'mains load inhibit' is active.

75 MAINS LOW FREQUENCY

This output indicates that the unit has sensed that the incoming AC mains supply frequency has fallen below the frequency setting.

76 MAINS LOW VOLTAGE

This output indicates that the unit has sensed that the incoming AC mains supply voltage has fallen below the voltage limit setting.

77 MAINS OPEN BREAKER

This output used to control the load switching device. For Details see: "BREAKERS Page" section.

78 NO LOADING COMMAND

This output indicates that the unit is not calling of the generator contactor or breaker to be closed. Should the unit close the generator contactor this output will become inactive.

79 OIL PRESSURE LOW PRE-ALARM

This output indicates that a low oil pressure warning (pre-alarm) has occurred.

80 OIL PRESSURE LOW SHUTDOWN

This output indicates that a low oil pressure shutdown has occurred.

81 CONFIGURABLE ANALOG INPUT-1 HIGH PRE-ALARM

This output indicates that a high analog input-1 warning (pre-alarm) has occurred.

82 CONFIGURABLE ANALOG INPUT-1 HIGH SHUTDOWN

This output indicates that a high analog input-1 shutdown has occurred.

83 OVER CURRENT PRE-ALARM

This output indicates that the over current pre-alarm has been reached.

84 OVER CURRENT ALARM

This output indicates that the over current trip level has been reached.

85 OVER POWER PRE-ALARM

This output indicates that the over power pre-alarm has been reached.

86 OVER POWER SHUTDOWN

This output indicates that the over power shutdown has been reached.

87 OVER SPEED PRE-ALARM

This output indicates that the over speed warning (pre-alarm) has occurred.

88 OVER SPEED SHUTDOWN

This output indicates that the over speed shutdown has occurred.

89 PANEL LOCK

This output indicates that the unit 'panel lock' is active. If the panel lock input is active, the unit will not respond to operation of the Mode select or start buttons. This allows the unit to be placed into a specific mode (such as auto) and then secured.

90 PRE-HEAT(during preheat timer)

The output controls the pre-heater. Pre-heat output is available for the duration of pre-heat timer, which terminates prior to cranking.

91 PRE-HEAT(until end of cranking)

The output controls the pre-heater. As 'Pre-heat (during pre-heat timer)' mode but pre-heat is also available during cranking.

92 PRE-HEAT(until end of warming)

The output controls the pre-heater. As 'Pre-heat (until safety on)' but pre-heat continues to be available until the warm-up timer has elapsed.

93 PRE-HEAT(until end safety on)

The output controls the pre-heater. As 'Pre-heat (until end of cranking)' but pre-heat is also available while waiting for the delayed alarms to become active.

94 REMOTE START PRESENT

This output indicates that a digital input that has been configured as 'remote start' is active. This output could be used to pass the remote start signal on to else where in the control system.

95 REMOTE STOP DELAY IN PROGRESS

This output source will be active to indicate that the return timer is running.

96 SHORT CIRCUIT

This output indicates that the module has detected a short circuit on the generator output.

97 SMOKE LIMITING

This output is used to supply a smoke-limiting signal to an Electronic Governor to limit smoke emissions on start-up. It is used in conjunction with the Smoke limit timer (Idle mode timer) settings. Once the timer has expired, the Smoke limit output will cease to operate allowing the engine to accelerate to normal running speed.

98 STARTING ALARM

This output is used to supply an external sounder with a signal that the engine is about to start. The output will be active during the start delay and pre-heat timer (if used).

99 STARTING ALARMS ARMED

The output indicates that the starting alarms are now enabled. It can be used to control external logic circuitry. Starting alarms are armed as soon as the unit commences starting of the engine and remain armed until the engine at rest.

100 STOP RELAY ENERGISED

The output mimics the operation of the stop relay. Can be used to control external logic circuitry.

101 SYSTEM IN AUTO MODE

The output indicates that the unit is in the Auto mode.

102 SYSTEM IN MANUAL MODE

The output indicates that the unit is in the Manual mode.

103 SYSTEM IN STOP MODE

The output indicates that the unit is in the Stop mode.

104 SYSTEM IN TEST MODE

The output indicates that the unit is in the Test mode.

105 UNDER CURRENT PRE-ALARM

This output indicates that the under current pre-alarm has been reached.

106 UNDER CURRENT ALARM

This output indicates that the under current trip level has been reached.

107 UNDER POWER PRE-ALARM

This output indicates that the under power pre-alarm has been reached.

108 UNDER POWER SHUTDOWN

This output indicates that the under power shutdown has been reached.

109 UNDER SPEED PRE-ALARM

This output indicates that an under speed warning (pre-alarm) has occurred.

110 UNDER SPEED SHUTDOWN

This output indicates that an under speed shutdown has occurred.

111 WAITING FOR GENERATOR

This output indicates that the engine has been instructed to start but has not yet become available. Once the generator becomes available this output will be in-active.

112 DUAL COMMUNICATION ERROR

This output indicates that a dual communication alarm has occurred.

113 LOAD SUPPLY FROM GENERATOR

This output indicates that the load is supplying from generator.

114 LOAD SUPPLY FROM MAINS

This output indicates that the load is supplying from mains.

115 CONFIGURABLE ANALOG INPUT-1 LOW PRE-ALARM

This output indicates that a low configurable analog input-1 warning (pre-alarm) has occurred.

116 CONFIGURABLE ANALOG INPUT-1 LOW SHUTDOWN

This output indicates that a low analog input-1 shutdown has occurred.

117 CONFIGURABLE ANALOG INPUT-2 LOW PRE-ALARM

This output indicates that a low configurable analog input-2 warning (pre-alarm) has occurred.

118 CONFIGURABLE ANALOG INPUT-2 LOW SHUTDOWN

This output indicates that a low analog input-2 shutdown has occurred.

119 CONFIGURABLE ANALOG INPUT-2 HIGH PRE-ALARM

This output indicates that a high analog input-2 warning (pre-alarm) has occurred.

120 CONFIGURABLE ANALOG INPUT-2 HIGH SHUTDOWN

This output indicates that a high analog input-2 shutdown has occurred.

121 CHOKE ACTIVE

This output becomes active everytime generator cranks and stays active until the choke time expires.

122 REMOTE CONTROL ACTIVE

This output indicates that the engine is being controlled remotely.

123 REVERSE POWER

This output becomes active when generator's active power drops below the Reverse Power Set value.

124 CABIN TEMPERATURE LOW PRE-ALARM

This output indicates that a low cabin temperature warning (pre-alarm) has occurred.

125 CABIN TEMPERATURE LOW SHUTDOWN

This output indicates that a low cabin temperature shutdown has occurred.

126 CABIN TEMPERATURE HIGH PRE-ALARM

This output indicates that a high cabin temperature warning (pre-alarm) has occurred.

127 CABIN TEMPERATURE HIGH SHUTDOWN

This output indicates that a high cabin temperature shutdown has occurred.

128 HEATER CONTROL

Becomes active when the Coolant Temperature falls below the "Heater control ON" setting. If the output is already active it will become inactive when the Coolant Temperature is above the "Heater control OFF" setting.

129 REMOTE OUTPUT

This output indicates that the output can be energised or de-energised remotely.

130 UNBALANCE LOAD

This output indicates "out of balance" current loading of the generator. Sometimes also called Negative Sequence Current or Symmetry Fault.

131 WATER PUMP

This output becomes active for the "Water pump on time" parameter and passive for the "Water pump off time" parameter while the "Heater control output" was active.

132 RESERVED**133 RESERVED****134 RESERVED****135 RESERVED****136 SYNCHRON POSITION**

This output will be active active when the synchronization process starts. This output will be passive when the synchronous operation ends.

137 OVER LOAD STEP 1

This output indicates that the over load step 1 level has been reached.

138 OVER LOAD STEP 2

This output indicates that the over load step 2 level has been reached.

4.2.7 Timers

START TIMERS (<i>Timers->Start timers</i>)		Min	Max	Default	Unit
Mains transient delay	Mains Transient Delay	0.0	20.0	2.0	Sec
Mains fail start delay	Mains Fail Start Delay	0	9999	0	Sec
Remote start delay	Remote Start Delay	0	3600	4	Sec
Pre-heat	Pre-Heat	0	250	3	Sec
Pre-heat bypass	Pre-Heat Bypass	0	250	0	Min
Safety on delay	Safety On Delay	0	99	5	Sec
Warming up time	Warmup Time	0	250	3	Sec
Horn duration	Horn Duration	0 (dis)	999	60	Sec
Chg. excitation time	Charge Excitation Time	0	99(cont)	15	Sec
Cooling fan time	Cooling Fan Time	0	250	180	Sec
Idle mode time	Idle Mode Time (Smoke Limiting)	0 (dis)	3600	dis	Sec
Idle mode time off	Idle Mode Time Off (Smoke Limiting Off)	0	250	5	Sec

Mains Transient Delay

The unit uses this parameter to decide the mains fail.

Mains Fail Start Delay

This timer dictates how long the unit will wait after it has received a mains failure signal before it will attempt to start. This prevent un-necessary starting on a fluctuating mains supply etc.

Remote Start Delay

This timer dictates how long the unit will wait after it has received a remote start signal before it will attempt to start. This prevent un-necessary starting on a fluctuating mains supply etc.

Pre-Heat

This timer dictates the duration that the pre-heat output will be active before an attempt is made to start the engine. Once this timer is expired cranking will commence.

Pre-Heat Bypass

This feature allows the unit to start a hot engine without performing an un-necessary pre-heat delay. The bypass timer is triggered by the generator starting and actually being loaded. If the generator started but does not achieve loading then the timer will not be triggered. The bypass timer is initiated once the engine has come to rest. If any attempts to start are requested within the duration of the bypass timer the start sequence will bypass the pre-heat timer.

Safety On Delay

This timer dictates how long the unit will ignore the Low Oil Pressure, High Engine Temperature, Underspeed, Undervolts and any other inputs configured as active from safety on. It allows the values such as oil pressure to rise to their operating values on starting without triggering an alarm. Once the timer has expired all alarm conditions are monitored again. If configured to use 'fast loading', should all the monitored conditions, such as oil pressure, come to expected state prior to the end of the safety on timer, the timer will be terminated prematurely ensuring maximum protection as soon as possible.

Warmup Time

This timer is initiated once the engine is up and running. It delays loading the generator until it has stabilised. Once this timer is expired the 'Close generator' signal will be given and the generator is available to be loaded.

Horn Duration

This timer dictates how long the external horn and the internal sounder will work after the last error detected. Once after this timer ended unit will do the external horn and the internal sounder reset.

Charge Excitation Time

Charge excitation was selectable as momentary / continuous operation. This timer dictates how long the Charge excitation will active.

Note: dis = disable cont = continuous

Cooling Fan Time

This timer dictates how long the Cooling Fan will continue to operate.

Idle Mode Time (Smoke Limiting)

This is the amount of time that the smoke limiting output will remain active for once the engine has started. While the smoke limiting output is active the engine will be held at a reduced speed to minimise smoke emissions on start-up. (Only if fitted with an appropriate Electronic Control Module). Once the timer has expired the engine will be allowed to accelerate up to its normal operating speed.

Idle Mode Time Off (Smoke Limiting Off)

This timer is started after the Idle mode timer (smoke limit timer) was expired. This is to allow the engine to accelerate to its normal running speed without triggering an underspeed alarm, etc.

STOPPING TIMERS (<i>Timers->Stopping timers</i>)		Min	Max	Default	Unit
Mains return delay	Mains Return Delay	0	3600	5	Sec
Remote stop delay	Remote Stop Delay	0	250	4	Sec
Cooling time	Cooling Time	0 (dis)	3600	60	Sec
Fail to stop delay	Fail To Stop Time	15	999	30	Sec
Battery charging time	Battery Charging Time	1	9999	5	Min
Idle stop time	Idle Stop Time	0 (dis)	3600	dis	Sec

Mains Return Delay

This timer dictates how long the unit will wait before it will un-load the generator (back to the mains supply if AMF) and initialise it's run-on and shutdown cycle. This is ensure that the mains supply has stabilised before transferring the load back to mains.

Remote Stop Delay

This timer dictates how long the unit will wait after it has received a remote stop signal before it will attempt to stop. This prevent un-necessary stopping on a fluctuating mains supply etc.

Cooling Timer

This is the time the generator is to run off-load once the load transfer signal has ceased. This gives the engine time to cool down before shutdown.

Fail To Stop Time

Once the unit has given a shutdown signal to the engine it expects the engine to come to rest. It monitors the Oil pressure and speed sensing sources and if they still indicate engine movement when this timer expires a 'Fail To Stop' alarm signal is generated.

Battery Charging Time

In AUTO mode and no mains, if one of the configurable inputs are selected as "24-Low Battery" and this input is active, the unit will perform the start sequence. When the mains back or "Battery Charging Time" parameter is expired, the unit will perform the stop sequence.

Idle Stop Time

This parameter specifies the duration of the motor to run at idle before it stops.

4.2.8 Expansion Modules

IO (1-8) MODULE (<i>Expansion modules->IO (1-8)</i>)		Min	Max	Default	Unit
Disable/enable select	Expansion I/O Module Selection	ENABL/DISBL		DISBL	

DIAL-UP & ETHERNET (<i>Expansion modules->Dial-up & Ethernet</i>)		Min	Max	Default	Unit
Disable/enable select	Expansion Dal-up&Ethernet Module Selection	ENABL/DISBL		ENABL	
Call back selection	Call Back Selection	ENABL/DISBL		DISBL	

Note: dis = disable

GPRS MODULE (Expansion modules->GPRS)		Min	Max	Default	Unit
Disable/enable select	Expansion GPRS Module Selection	0-DISABLE 1-GPRS SERVER 2-GPRS CLIENT 3-SMS		1-GPRS SERVER	
Call back selection	Call Back Selection	ENABL/DISBL		DISBL	
Cell inf refresh rate	Cell info refresh rate	0(dis)	999	2	Min
Location data	Location data	ENABL/DISBL		DISBL	
Location warning	Location warning	1(dis)	999	1(dis)	Km

DUAL SET MODULE (Expansion modules->Dual set)		Min	Max	Default	Unit
Disable/enable select*¹	Expansion Dual Set Module Selection	ENABL/DISBL		ENABL	
Node ID*²	Node Address	1	2	1	
Working period	Dual Working Period	0:00	98:59	1:00	H.Min
Early start time	Early Start Time	0	250	15	Sec
Remote priority selct	Remote Priority Selection: 0- Disable, 1- Priority, 2- None Priority	0(dis)	2	dis	

GPRS WEB MODULE (Expansion modules->GPRS Web)		Min	Max	Default	Unit
Disable/enable select	GPRS-Web Module Selection	ENABL/DISBL		ENABL	

4.2.9 Synchronization

SYNCH CHECK (Synchronization->Synch Check)		Min	Max	Default	Unit
Synchronization check	Synchronization check enable/disable	ENABL/DISBL		DISBL	
Synced working time	Synced working time	0.0	25.0	0.5	Sec
Synch. fail time	Synchronization fail time	0	250	30	Sec
Max voltage diff.	Max voltage difference	0	20	5	V _~
Voltage type	Voltage type	0=Ph-N / 1=Ph-Ph		0=Ph-N	
Max frequency diff.	Max frequency difference	0.0	2.0	0.5	Hz
Max angle difference	Max angle difference	0	20	10	°
Angle offset	Angle offset	-150	+150	0	°
Show synch fail	Show synchronization fail	ENABL/DISBL		ENABL	

Synchronization check enable/disable

The user can be enable or disable the uninterrupted load transfer with this parameter.

Synced working time

During this timer, both contactors will be active.

Synchronization fail time

When this timer is expired, if the Generator L1 and Mains L1 voltages are still not synchronized; the unit gives synchronization error and performs interrupted load transfer.

Maximum voltage difference

During synchronization process, difference between average Generator voltage and average Mains voltage must be in this limit.

Voltage type

The user can select voltage difference type to be calculated with this parameter;

Maximum frequency difference

During synchronization process, frequency difference between Gen. and Mains must be in this limit.

Note: *1 = Changing this parameter becomes only effective after restarting the unit.

*2 = Changing this parameter becomes only effective after restarting the unit.

dis = disable.

Maximum angle difference

During synchronization process, angle difference between Gen. L1 and Mains L1 must be in this limit.

Angle offset

The user can give an offset to angle difference between Gen. L1 and Mains L1 with this parameter.

Show synchronization fail

DISABLE: When the “Synchronization fail” is occurred, the unit will not display related alarm message and activate horn output. The unit only will log this event.

ENABLE: When the “Synchronization fail” is occurred, the unit will display related alarm message, activate horn output and log this event.

4.2.10 User Adjustment

MAINS VOLTAGE OFFSET (User adjustment->Mains voltage offset)		Min	Max	Default	Unit
Mains V1 offset	Mains V1 Offset	-20	20	0	V \sim
Mains V2 offset	Mains V2 Offset	-20	20	0	V \sim
Mains V3 offset	Mains V3 Offset	-20	20	0	V \sim

GEN. VOLTAGE OFFSET (User adjustment->Gen. voltage offset)		Min	Max	Default	Unit
Gen. V1 offset	Generator V1 Offset	-20	20	0	V \sim
Gen. V2 offset	Generator V2 Offset	-20	20	0	V \sim
Gen. V3 offset	Generator V3 Offset	-20	20	0	V \sim

CURRENT OFFSET (User adjustment->Current offset)		Min	Max	Default	Unit
Current I1 offset	Current I1 Offset	-20	20	0	A \sim
Current I2 offset	Current I2 Offset	-20	20	0	A \sim
Current I3 offset	Current I3 Offset	-20	20	0	A \sim
E/F. Current offset	Earth current I3 Offset	-20	20	0	A \sim

BATTERY&CHRG GEN.VOL (User adjustment->Battery&chrg gen.vol)		Min	Max	Default	Unit
Batt.volt offset	Battery Voltage Offset	-5.0	5.0	0	V ---
Gen.chg.volt offset	Charge Generator Voltage Offset	-5.0	5.0	0	V ---

SENDER INPUTS OFFSET (User adjustment->Sender inputs offset)		Min	Max	Default	Unit
Oil Pressure offset	Oil Pressure Offset	-2.0	2.0	0.0	BAR
Temperature offset	Coolant Temperature Offset	-20	20	0	°C
Conf. AI1 offset	Configurable Analog Input-1 Offset	-200	200	0	%
Conf. AI2 offset	Configurable Analog Input-2 Offset	-20	20	0	°C

Error Messages And Explanations:

Battery high error! : Battery high error
Battery low error! : Battery low error
Battery high warning! : Battery high error
Battery low warning! : Battery low error
Cab temp.high error! : Cabin temperature high error
Cab temp.high preal! : Cabin temperature high pre-alarm
Cab temp.low error! : Cabin temperature low error
Cab temp.low preal! : Cabin temperature low pre-alarm
Can bus warning! : Can bus error
Charge alterntn fail! : Charge alternator fail
Conf. AI1 high error! : Configurable analogue input-1 high error
Conf. AI1 high preal! : Configurable analogue input-1 high pre-alarm
Conf. AI1 low error! : Configurable analogue input-1 low error
Conf. AI1 low preal! : Configurable analogue input-1 low pre-alarm
Conf. AI1 sensor err! : Configurable analogue input-1 sensor break
Conf. AI2 high error! : Configurable analogue input-2 high error
Conf. AI2 high preal! : Configurable analogue input-2 high pre-alarm
Conf. AI2 low error! : Configurable analogue input-2 low error
Conf. AI2 low preal! : Configurable analogue input-2 low pre-alarm
Conf. AI2 sensor err! : Configurable analogue input-2 sensor break
Dual communicat. err! : Dual communication error
E/F. instant trip! : Earth fault error
E/F. warning! : Earth fault warning
E/F.trip with cool.! : Earth fault electrical trip
Emergency stop! : Emergency stop error
Exp.spare-1 alarm! : Expansion module spare 1 error
Exp.spare-2 alarm! : Expansion module spare 2 error
Exp.spare-3 alarm! : Expansion module spare 3 error
Exp.spare-4 alarm! : Expansion module spare 4 error
Exp.spare-5 alarm! : Expansion module spare 5 error
Exp.spare-6 alarm! : Expansion module spare 6 error
Exp.spare-7 alarm! : Expansion module spare 7 error
Exp.spare-8 alarm! : Expansion module spare 8 error
Fail to start alarm! : Fail to start alarm
Fuel filling alarm! : Fuel filling alarm
Gen break.close fail! : Generator breaker not closed alarm
Gen break.open fail! : Generator breaker not opened alarm
Gen over frq.preal! : Generator over frequency pre-alarm
Gen over frq.shutdwn! : Generator over frequency shutdown
Gen over vol.shutdwn! : Generator over voltage shutdown
Gen over volt.preal! : Generator over voltage prealarm
Gen phase seq.wrong! : Generator phase sequence wrong
Gen stop fail! : Generator stop error
Gen under frq.preal! : Generator under frequency pre-alarm
Gen under frq.shtdwn! : Generator under frequency shutdown
Gen under vol.shtdwn! : Generator under voltage shutdown
Gen under volt.preal! : Generator under voltage pre-alarm
High temp.prealarm! : Temp pre-alarm
High temp.shutdown! : High temp. shutdown
J1939 ECU warning! : Amber warning lamp error
Low temperature! : Low temperature
Mains break.cls fail! : Mains breaker not closed alarm
Mains break.opn fail! : Mains breaker not opened alarm
Mains phase seq. err! : Mains phase sequence error
Maintenance alarm! : Maintenance error
Oil press.shutdown! : Pressure shutdown
Over curr.trip cool.! : Over current electrical trip
Over current preal! : Over current pre-alarm
Over current trip! : Over current error
Over current warnng! : Over current warning
Over load step 1 alr! : Over load step 1 alarm
Over load step 2 alr! : Over load step 2 alarm
Over power alarm! : Over power error
Over power prealarm! : Over power pre-alarm
Over power trip cool! : Over power electrical trip

Error Messages And Explanations:

Over power warning! : Over power warning
Over speed alarm! : Over speed error
Over speed prealarm! : Over speed pre-alarm
Pressure prealarm! : Pressure prealarm
Pressure sensor err! : Oil pressure sensor break
Red stop lamp! : Red stop lamp error
Reverse power warnng! : Reverse power Warning
Rev.power trip cool.! : Reverse power Electrical Trip
Reverse power trip! : Reverse power Error
Short circuit trip! : Short circuit error
Spare-1 alarm! : Spare 1 error
Spare-2 alarm! : Spare 2 error
Spare-3 alarm! : Spare 3 error
Spare-4 alarm! : Spare 4 error
Spare-5 alarm! : Spare 5 error
Spare-6 alarm! : Spare 6 error
Spare-7 alarm! : Spare 7 error
Speed loss alarm! : Speed loss error
Synchronization alarm! : Synchronization alarm
Temperat. sensor err! : Temperature sensor break
Unbalance load trip! : Unbalance load error
Unbal.load trip cool! : Unbalance load electrical trip
Unbalance load warn.! : Unbalance load warning
Under curr.trip cool! : Under current electrical trip
Under current preal! : Under current pre-alarm
Under current trip! : Under Current error
Under current warnng! : Under Current Warning
Under power prealarm! : Under power prealarm
Under power trip! : Under power error
Under pow.trip cool! : Under power electrical trip
Under power warning! : Under power warning
Under speed prealarm! : Under speed prealarm
Under speed trip! : Under speed error

Event Messages And Explanations:

Battery high alarm : Battery high error
Battery low alarm : Battery low error
Cab temp.high error : Cabin temperature high error
Cab temp.high prealr : Cabin temperature high pre-alarm
Cab temp.low error : Cabin temperature low error
Cab temp.low prealr : Cabin temperature low pre-alarm
Can bus warning : Can bus error
Changed mode to auto : Changed mode to auto
Changed mode to man : Changed mode to manual
Changed mode to stop : Changed mode to off
Changed mode to test : Changed mode to test
Charge alterntr fail : Charge alternator fail
Conf. AI1 high error : Configurable analogue input-1 high error
Conf. AI1 high preal : Configurable analogue input-1 high pre-alarm
Conf. AI1 low error : Configurable analogue input-1 low error
Conf. AI1 low prealr : Configurable analogue input-1 low pre-alarm
Conf. AI1 sensor err : Configurable analogue input-1 sensor break
Conf. AI2 high error : Configurable analogue input-2 high error
Conf. AI2 high preal : Configurable analogue input-2 high pre-alarm
Conf. AI2 low error : Configurable analogue input-2 low error
Conf. AI2 low prealr : Configurable analogue input-2 low pre-alarm
Conf. AI2 sensor err : Configurable analogue input-2 sensor break
Dual communicat. err : Dual communication error
E/F. alarm : Earth fault alarm
Emergency stop : Emergency stop error
Engine started : Engine started
Engine stopped : Engine stopped
Exp.spare-1 alarm : Expansion module spare 1 error
Exp.spare-2 alarm : Expansion module spare 2 error
Exp.spare-3 alarm : Expansion module spare 3 error

Event Messages And Explanations:

Exp.spare-4 alarm : Expansion module spare 4 error
Exp.spare-5 alarm : Expansion module spare 5 error
Exp.spare-6 alarm : Expansion module spare 6 error
Exp.spare-7 alarm : Expansion module spare 7 error
Exp.spare-8 alarm : Expansion module spare 8 error
Fail to start alarm : Fail to start alarm
Fuel filling alarm : Fuel filling alarm
Gen break.close fail : Generator breaker not closed alarm
Gen break.open fail : Generator breaker not opened alarm
Gen over frq.prealr : Generator over frequency pre-alarm
Gen over frq.shutdwn : Generator over frequency shutdown
Gen over vol.prealr : Generator over voltage pre-alarm
Gen over vol.shutdwn : Generator over voltage shutdown
Gen phase seq.wrong : Generator phase sequence wrong
Gen stop fail : Generator stop error
Gen under frq.preal : Generator under frequency pre-alarm
Gen under frq.shtdwn : Generator under frequency shutdown
Gen under vol.preal : Generator under voltage pre-alarm
Gen under vol.shtdwn : Generator under voltage shutdown
GPRS IP not found : Gprs no IP alarm
GPRS reset fail : Gprs reset fail
High temp.prealarm : High temp. pre-alarm
High temp.shutdown : High temp. shutdown
J1939 ECU warning : Amber warning lamp error
Low temperature : Low temperature
Mains break.cls fail : Mains breaker not closed alarm
Mains break.opn fail : Mains breaker not opened alarm
Mains phase seq. err : Mains phase sequence error
Maintenance alarm : Maintenance error
Maintenance warning : Maintenance warning
Modem response: error : Gprs error response alarm
No respons.from modem : Gprs no response alarm
Oil press.shutdown : Pressure shutdown
Over current alarm : Over current alarm
Over current prealr : Over current pre-alarm
Over load step 1 alr : Over load step 1 alarm
Over load step 2 alr : Over load step 2 alarm
Over power alarm : Under power error
Over power prealarm : Under power pre-alarm
Over speed prealarm : Over speed pre-alarm
Over speed shutdown : Over speed shutdown
Pressure prealarm : Pressure prealarm
Pressure sensor err : Oil pressure sensor break
Red stop lamp : Red stop lamp error
Reverse power alarm : Reverse power alarm
Short circuit alarm : Short circuit alarm
SMS was not sent : Sms wasn't sent
SMS was sent : Sms was successfully sent
Spare-1 alarm : Spare 1 error
Spare-2 alarm : Spare 2 error
Spare-3 alarm : Spare 3 error
Spare-4 alarm : Spare 4 error
Spare-5 alarm : Spare 5 error
Spare-6 alarm : Spare 6 error
Spare-7 alarm : Spare 7 error
Speed loss alarm : Magnetic pickup loss of speed error
Synchronization alarm : Synchronization alarm
Temperat. sensor err : Temperature sensor break
Unbalance load alarm : Unbalance load alarm
Under current alarm : Under current error
Under current prealr : Under current pre-alarm
Under power alarm : Under power error
Under power prealarm : Under power pre-alarm
Under speed prealarm : Under speed pre-alarm
Under speed shutdown : Under speed shutdown

5. Specifications

Equipment use	: Electrical control equipment for generating sets.
Housing & Mounting	: 229 mm x 152 mm x 41 mm. (including connectors). Plastic housing for panel mounting.
Panel Cut-Out	: 182mm x 135mm.
Protection	: IP65 at front panel.
Weight	: Approximately 0,53 Kg.
Environmental rating	: Standard, indoor at an altitude of less then 2000 meters with non-condensing humidity.
Operating/Storage Temperature	: -20°C to +70°C / -30°C to +80°C
Operating/Storage Humidity	: 95 % max. (non-condensing)
Vibration	: EN 60068-2-6 Ten sweeps in each of three major axes 5Hz to 8Hz @ +/-7.5mm, 8Hz to 500Hz @ 2gn.
Shock	: EN 60068-2-27 Three shocks in each of three major axes 15gn in 11mS.
Installation Over Volt. Category	: II Appliances, portable equipment
Pollution Degree	: II, Normal office or workplace, non conductive pollution
Mode of Operation	: Continuous.
DC Battery Supply Voltage	: 8 to 32 V _{DC} (Peak: 36 V _{DC}). Max. operating current is 360mA.
Cranking Dropouts	: Battery voltage can be "0" VDC for max. 50 ms during cranking (battery voltage should be at least nominal voltage before cranking).
Battery Voltage Measurement	: 8 to 32 V _{DC} , accuracy: 1 % FS, resolution: 0,1 V
Mains Voltage Measurement	: 10 to 300 VAC Ph-N, 5 to 99.9 Hz. Accuracy: 1 % FS, Resolution: 1 V, Harmonics: Up to 11 th .
Mains Frequency	: 5 to 99.9Hz (min. 20 VAC Ph-N) Accuracy: 0,25 % FS, Resolution: 0,1 Hz.
Generator Voltage Measurement	: 10 to 300 VAC Ph-N, 5 to 99.9 Hz. Accuracy: 1 % FS, Resolution: 1 V, Harmonics: Up to 11 th .
Generator Frequency	: 5 to 99.9Hz (min. 20 VAC Ph-N) Accuracy: 0,25 % FS, Resolution: 0,1 Hz.
Magnetic Pickup Input	: 35 to 10000 Hz (1 to 35 volts peak continuously). Accuracy: 0,25 % FS.
CT secondary	: 5A.
Charge Generator Excitation	: 210mA @12V, 105mA @24V. Nominal 2.5W.
Charge Gen. Vol. Measurement	: 8 to 32 V _{DC} , accuracy: 1 % FS, resolution: 0,1 V.
Sender Measurement	: 0 to 1300 ohm, accuracy: 1 % FS, resolution: 1 ohm.
Canbin Temp. Measurement	: -50 to +100 °C, accuracy: 1 % FS, resolution: 1 °C.
Communication interface	: USB programming and communication port, RS-485 (optional), CanBus communication with 1939 ECU.
Optional Expansion I/O Module	: Expansion I/O module including 8 inputs and 8 outputs.
Optional Comm. Modules	: Ethernet/Dial-up, GSM/GPRS, RS-232/485/422, Dual Set, Web Server and GPRS-Web modules.

Relay Outputs

: Generator contactor relay output 8A@250V~
Mains contactor relay output 8A@250V~
Configurable output-5 5A@250V~
Configurable output-6 5A@250V~

Transistor Outputs

: Fuel or Configurable output-1 1A at DC supply voltage
Crank or Configurable output-2 1A at DC supply voltage
Configurable output-3 1A at DC supply voltage
Configurable output-4 1A at DC supply voltage
All transistor outputs supplied from DC supply terminal 22

Approvals

: EAC , CE

6. Other Informations**Manufacturer Information:**

Emko Elektronik Sanayi ve Ticaret A.Ş.
Demirtaş Organize Sanayi Bölgesi Karanfil Sk. No:6 16369
BURSA/TURKEY

Phone : +90 224 261 1900

Fax : +90 224 261 1912

Repair and maintenance service information:

Emko Elektronik Sanayi ve Ticaret A.Ş.
Demirtaş Organize Sanayi Bölgesi Karanfil Sk. No:6 16369
BURSA/TURKEY

Phone : +90 224 261 1900

Fax : +90 224 261 1912



Thank you very much for your preference to use Emko Elektronik Products.

www.emkoelektronik.com.tr